

## Finite element-based models for the analysis of bolted beam-to-column steel connections

**Oreste BURSI**  
Research Associate  
Doctor Engineer  
Trento,  
ITALY

Oreste Bursi, born 1959, received his Mechanical Engineering Degree at the University of Padua, Italy. Since 1986, he has been at the University of Trento. His research interest is devoted to elastodynamics, structural plasticity and, finally, analysis and modelling of the behaviour of steel and steel-concrete composite structures.

**Jean-Pierre JASPART**  
Research Associate FNRS  
Doctor Engineer  
Liège,  
BELGIUM

Jean-Pierre Jaspert, born 1962, got his Civil Engineering Degree in 1985 and his Ph.D Degree in 1991 at the University of Liège. He is the author of more than 60 papers on steel connection and frame design, one of the members of the Drafting Group of EC3 Annex J and Chairman of the COST C1 Working Group on "Steel and Composite Connections".

### Summary

This paper presents parts of the results of a study devoted to the analysis of bolted steel connections by means of finite elements. In particular, the paper introduces elementary tee-stub connections which are endowed with different plastic failure mechanisms and can be adopted as benchmarks in the validation process of finite element software packages. The comparison between computed and measured values permits the effectiveness and the degree of accuracy of the proposed finite element models to be highlighted.

### 1. INTRODUCTION

Bolted connections are widely used in steel frames as simple or moment-resistant connections between steel members. Usually, they are designed to achieve "pinned" or "rigid" connections, though steel structures need often to have the lowest level of detailing compatible with design requirements. A solution to this problem has been obtained with the recent semi-rigid design philosophy. This approach provides greater freedom than simple or fully-continuous design because the properties of the connections are treated as variables in design, to be chosen to meet the individual requirements of each project. Hence, the knowledge of the joint response and how it affects frame performance becomes a prerequisite to the practical use of semi-rigid design [1].

The potential economic implication of connections on frame design and fabrication is also realized by modern codes, such as LRFD [2] and Eurocode 3 [3]. In particular, Eurocode 3 includes application rules in order to define explicitly the joint behaviour [4]. In this context, the finite element technique can represent a rational supplement to design.

The study presented in this paper has a twofold purpose: (i) to introduce elementary tee-stub connections which can be used as benchmarks in the validation process of finite element software packages for bolted connections; (ii) to present a rational approach to calibrate a finite element model able to reproduce the elastic-plastic behaviour of elementary tee-stub connections.

The paper describes the behaviour of elementary tee-stub connections and their simulations with the LAGAMINE software package [5] by means of bricks and contact elements. As explained in section 2, this work has followed by the simulation of the elastic-plastic behaviour of more realistic end plate connections to the ultimate limit state by means of the ABAQUS code [7,8], including both end plate-foundation and end plate-bolt interaction phenomena. Because of the limited number of pages, this part of the study (see [6]) is not described in the present paper.

## 2. Approach of the Study

Nowadays, latest generation research and commercial finite element codes are capable to simulate almost all the complex phenomena affecting the connection response (three-dimensional behaviour, combined non linear phenomena like material and geometrical nonlinearities, friction, slippage, contact, bolt-plate interaction and fracture, ...). However, still difficulties remain to the numerical analyst which has to choose appropriate finite element models able to provide an accurate representation of the physics with the lowest computational cost. Choice of mesh, node number, integration point number through the element thickness and time-step size for constitutive law integration depend upon resources, problem, geometry, type of loading and required accuracy .

To shed light on these problems, elementary non preloaded and preloaded tee-stub connections have been tested in laboratory by Jaspart [10] and Bursi [11]; they are proposed as benchmarks in the validation process of finite element software packages. These benchmarks have been simulated in a large displacement, large rotation and large deformation regime with the LAGAMINE software package [5], by means of bricks [12] as well as contact elements [13]. The choice of these elements as well as related aspects have been commented upon and the numerical results have finally been compared to the experimental ones, thus assessing the reliability of the finite element models.

A calibration phase has then been described in which specific elements of the ABAQUS library [8] have been chosen on the basis of test data as well as LAGAMINE [5] simulations. Then, additional simulations have been performed to validate an assemblage of beam elements, labelled spin, which is intended to reproduce in a simple, yet accurate manner, the bolt behaviour. Finally, the ABAQUS [7] code has been used to simulate the elastic-plastic behaviour of realistic end plate connections to the ultimate limit state. The comparison between computed and reference values in each phase has allowed to highlight the effectiveness and degree of accuracy of the proposed finite element models.

A detailed information concerning this work may be found in [6] and [9]. The main aspects of the first part (study of the benchmarks by LAGAMINE) are presented here below.

### 3. Simulation of tee-stub connections

#### 3.1 Experimental data used as references

In order to acquire basic experimental data, elementary tee-stub connections proposed by Jaspart [17] and, afterwards, by Bursi [18] within the Numerical Simulation Working Group of the European research project COST C1 "Civil Engineering Structural Connections" were tested to collapse. These specimens reflect different geometrical and strength parameters as well as bolt prestressing conditions. In the sequel, the specimens are labelled T1 and T2 and are represented with their geometrical characteristics in Fig. 1a and 1b, respectively. The stub beam specimens were obtained from the same IPE300 and HE220B profiles, respectively, to allow a direct comparison of performances among the specimens. Furthermore, they were designed purposely to fail according to the so-called Mode 1 and Mode 2 collapse mechanisms described in Eurocode 3 [3]. Fasteners were M12 grade 8.8 bolts. Within T1 and T2 specimens both non-preloaded and preloaded bolts were used. As a result, the overall test program comprised four tests.

A full detailed description of the test data and results is given in [9].

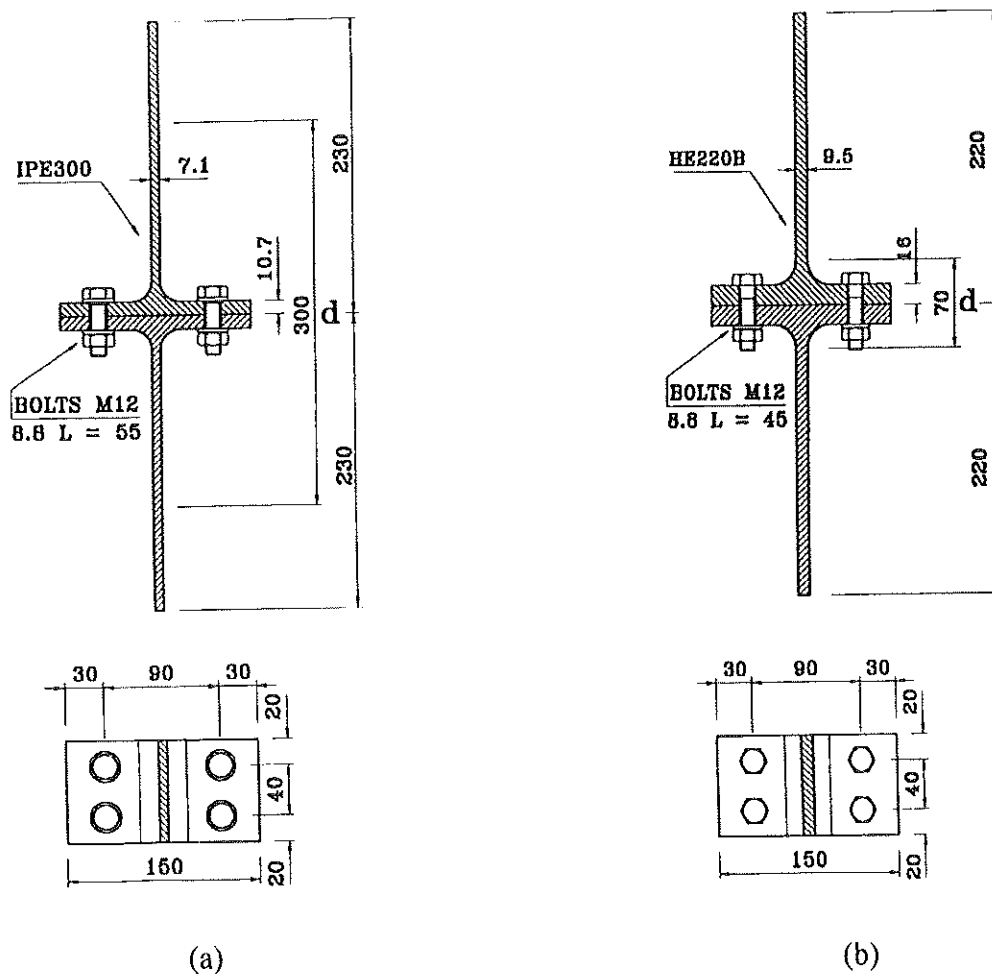

Fig. 1. Test specimens: (a) tee-stub connection T1; (b) tee-stub connection T2

### 3.2 Types of finite element

The LAGAMINE finite element package, developed at the MSM Department of the University of Liege to simulate metal-forming [5], i.e. processes characterized by large displacements, large rotations and large strains, has been used to predict the behaviour of the isolated tee-stub connections described above.

These elementary connections are proposed as benchmarks for finite element modelling, because they embody many typical features of bolted connections. In particular, the material discontinuity within these assemblages determines a relative movement of their constitutive components. In addition, these components are subjected to yielding while bearing of fasteners and elements determines stress concentrations or prying forces.

In order to minimize the number of modelling assumptions, those complex 3D phenomena have been reproduced by adopting both hexahedra [12] and contact [13] finite elements implemented in LAGAMINE. These are briefly described hereafter but the interested reader will find more information in [9].

Hexahedra elements are more popularly known as bricks. In the simulations of the tee-stub connections performed with LAGAMINE, use has been made of the three dimensional mixed brick element called JET3D [12] in which an assumed strain field within a mixed-multifield variational principle able to eliminate spurious energy-modes and a geometry dependent parameter set to control shear locking have been embodied.

The contact and distribution of interface stresses between two bodies are unknown during a contact process, and therefore, the contact problem turns out to be highly non-linear and with unknown boundary conditions. This phenomenon is simulated in LAGAMINE with contact elements which describe topologically surfaces and are located on the boundaries of solid elements. The contact condition is guaranteed by a penalty technique [13] which requires an optimal value for a penalty parameter. This parameter can be interpreted as the stiffness of a virtual spring between two bodies. As a result, contact constraints are satisfied only in the limit for an infinite penalty value. However, a too large penalty value can engender ill-conditioning of the stiffness matrix. Thus, its optimum value is traced when there is only a slight change in the results for an additional increase of the penalty parameter or, when the penetration reaches limited values.

### 3.3 Plate and bolt discretization

In Li's work [14], it is shown that, for bending-dominated problems, at least three-layers of JET3D brick elements have to be used to capture the stiffness and strength behaviour of a structure with a good accuracy.

In the examined specimens as well as in bolted connections, in general, bolts behave in a 3D fashion. Hence, they have also been modelled in the benchmarks by means of JET3D brick elements. Nevertheless in order to reduce the number of contact planes, washers have been considered attached to bolt heads and bolts have been assumed to be symmetric. To comply with these assumptions, the additional flexibilities provided by the nut and the threaded part

of the shank have been incorporated into an effective bolt length according to the Agerskov's model [15]. That model is based on the following equation:

$$\frac{E A_b}{K_1 + 2K_4} = \frac{B}{\Delta l_b} = \frac{E A_s}{L_{eff}} \quad (1)$$

where  $A_b$  and  $A_s$  indicate the gross cross-section and the tensile stress area, respectively,  $B$  and  $\Delta l_b$  define the bolt force and the corresponding bolt elongation while the effective length  $L_{eff}$  is unknown.  $K_1$  and  $K_4$  are parameters which can be obtained readily from the bolt geometry shown in Fig. 2. In detail, the following relations hold:

$$K_1 = l_s + 1.43l_t + 0.71l_n \quad K_4 = 0.1l_n + 0.2l_w \quad (2)$$

By noting that the threaded part of the bolt shank triggers off tensile yielding and failure, the bolt shank is reproduced with a cylinder of cross-section area  $A_s$ . With this assumption,  $L_{eff}$  can be obtained readily from Eq. (1).

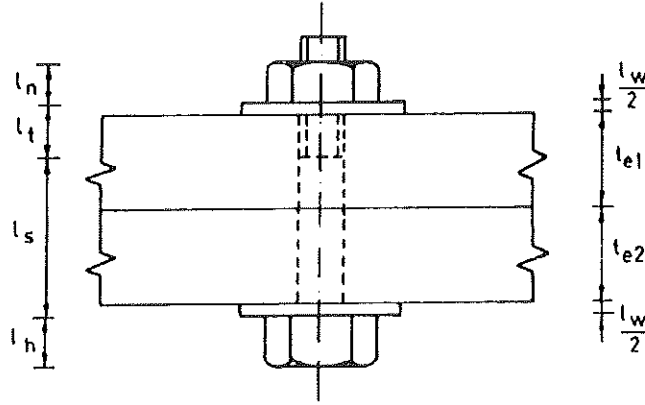

Fig. 2 Bolt geometry

### 3.4 Finite element results

Finite element analyses covered all four specimens. However, because of the limited number of pages, the results are described accurately for the preloaded specimen T1 only in the remainder of this section.

The displacement field at the plastic failure state traced by the finite element analysis is shown in Fig.3.a for the preloaded specimen T1. One can observe how the model is able to reproduce the flange kinematics and the relative movement between flange and bolt head. The corresponding distribution of von Mises equivalent stresses is reported in Fig. 3.b. The large stress fields in the flange near the bolt hole and close to the radius of fillet identify two yield lines which govern the kinematic mechanism observed at yielding. This failure mechanism agrees with the one predicted by Eurocode 3 (Mode 1).

The accuracy of the finite element model can be quantified by superimposing the computed load-displacement  $F - \Delta d$  relationships upon the measured one, as shown in Fig. 4. From the comparison one can observe the good accuracy of the simulation. Only some discrepancy is

evident at the onset of yielding, due to residual stress effects which determine a more gradual plastification of the specimen and which are disregarded in the model.

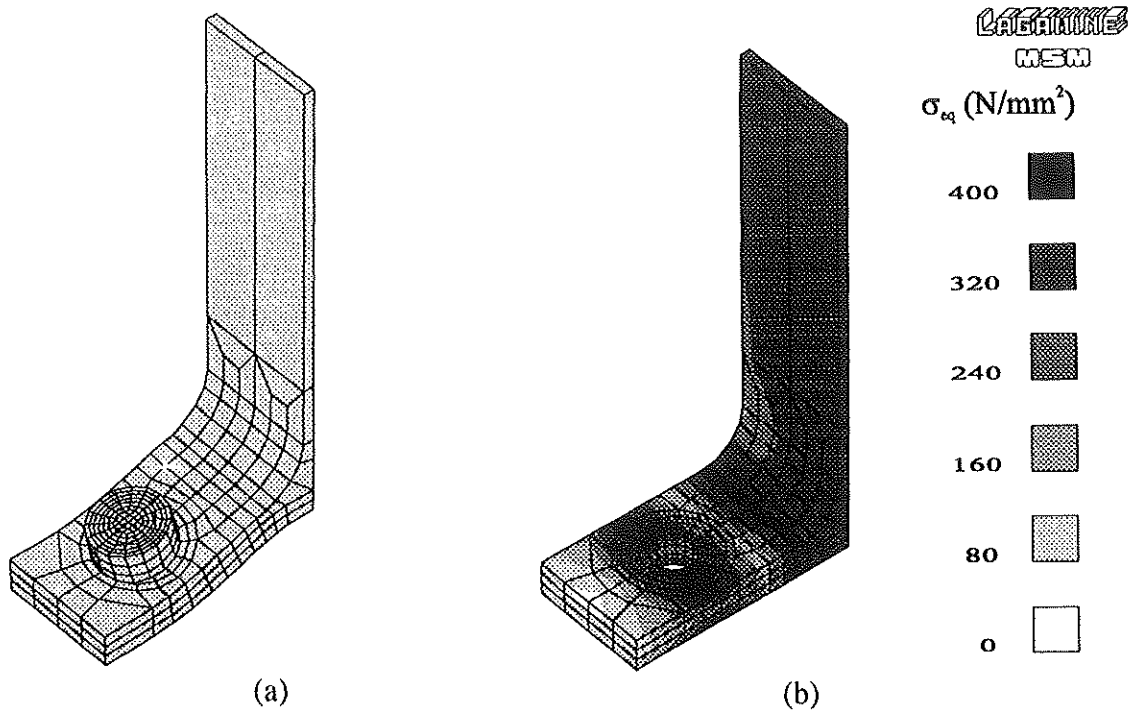

Fig. 3 Preloaded tee-stub T1 at the plastic failure state: (a) displacement field; (b) von Mises equivalent stress field

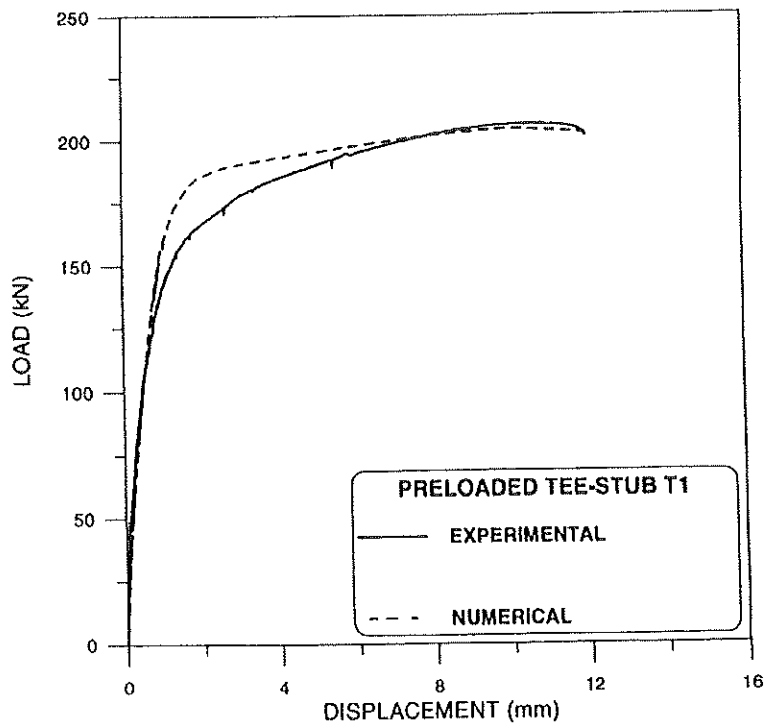

Fig.4 Experimental and predicted relative displacement  $\Delta d$  versus load  $F$  for the preloaded tee-stub T1

Once the finite element model is proved to be reliable, it can be used to generate information which cannot be provided from actual tests, because bolted connections appear to be highly redundant and confined physical systems. As an example, significant data can be obtained by plotting contact pressures developed between tee-stub flanges. Fig. 5 highlights the normal pressure distribution at the plastic failure state in the external part of the tee-stub. This distribution can be used to quantify the location and amplitude of prying forces.

The model can also provide detailed information on bolt behaviour. The evolution of von Mises stresses in each bolt and washer can be observed both at the preloaded state and at the plastic failure state of the tee-stub in Fig. 6.a and 6.b, respectively. Yielding can be observed in the bolt shank, indicating that also bolts participated in the plastic failure mechanism. In addition, from Fig. 6.b one can observe the stress level which affects the washers.

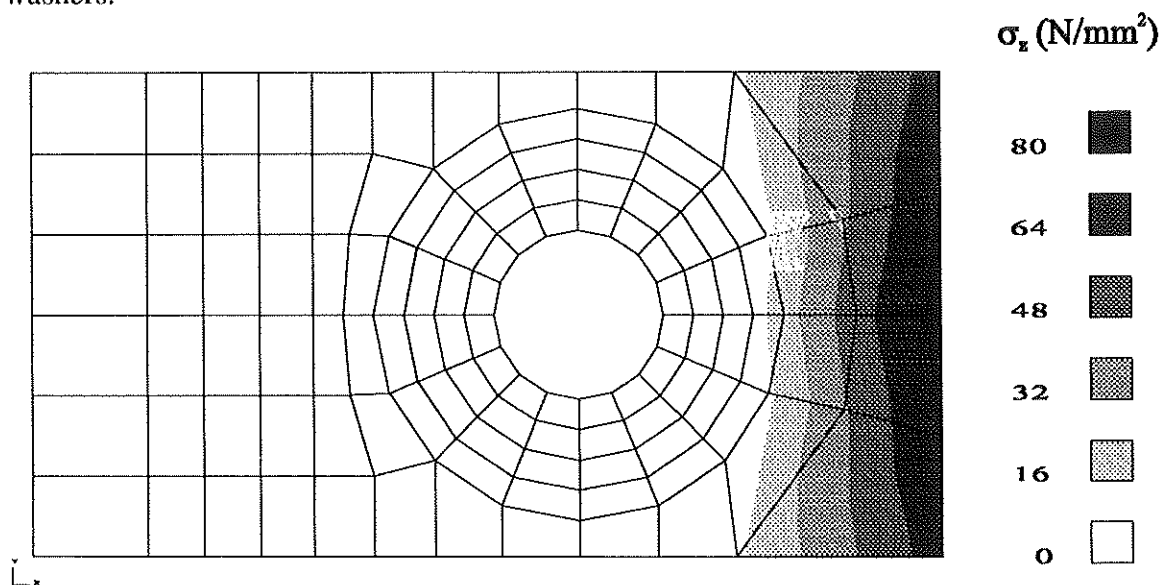

Fig. 5

Normal pressure distribution at the failure state for the preloaded tee-stub T1

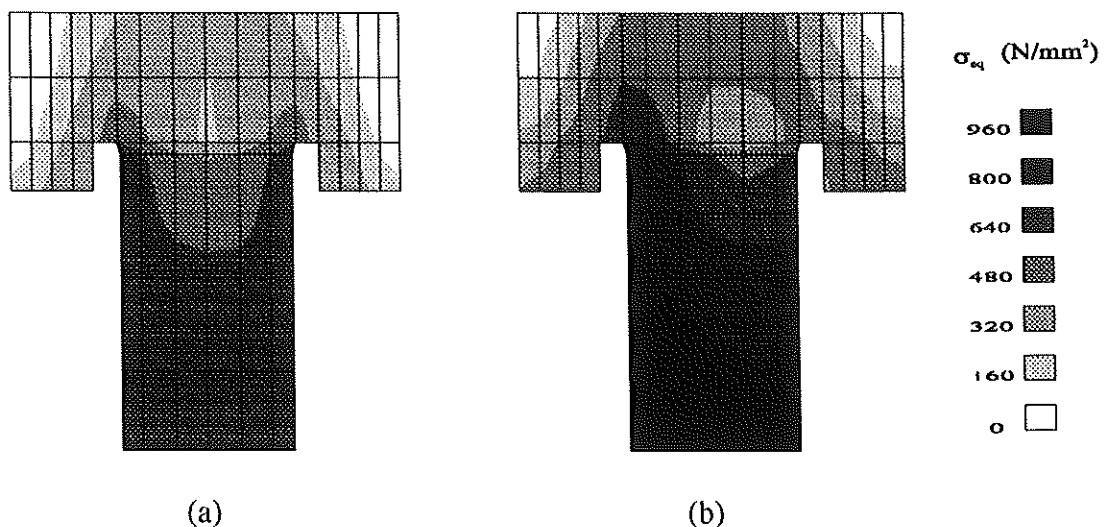

Fig.6 von Mises equivalent stress field of bolt in the preloaded tee-stub T1: (a) preloaded state; (b) plastic failure state

The curve giving the bolt axial force versus the applied total force is plotted in Fig. 7. From this relationship one can trace the evolution of the bolt force characterized by a first phase dominated by preloading effects followed by a growth of the bolt force due to prying effects. By means of this plot prying force values can be evaluated quite easily. In addition, bolt bending moment values can be evaluated too.

For brevity, the accuracy of the finite element model for the corresponding non-preloaded specimen is assessed by comparing the load-displacement relationship only. Such a comparison is shown in Fig. 8, where one can observe the accuracy of the simulation. Also for this case, a major discrepancy can be observed at the onset of yielding, where the actual plastification appears to be more gradual due to the residual stress effects.

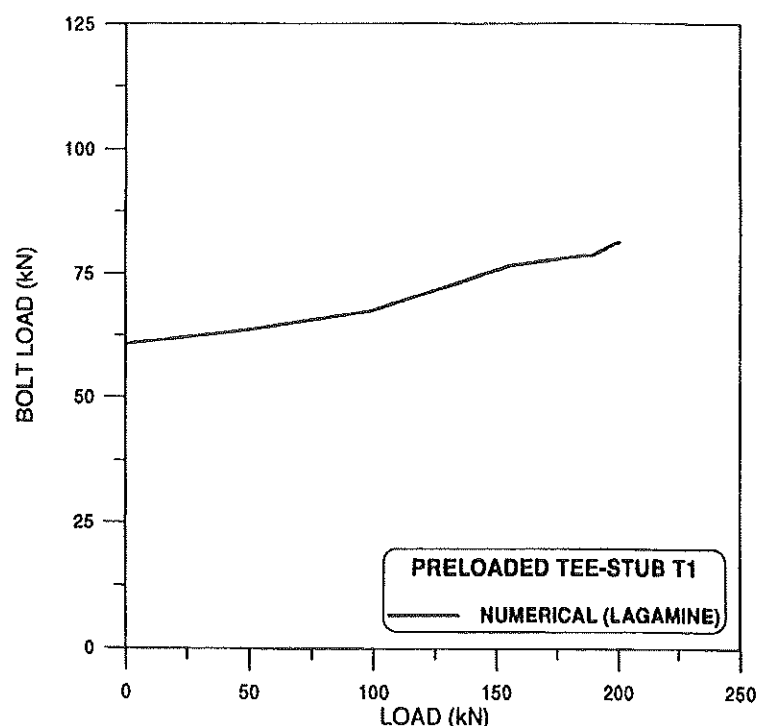

Fig. 7 Bolt axial force versus total force  $F$  for the preloaded tee-stub T1

#### 4. Conclusions

Parts of results of a study devoted to the analysis of bolted steel connections by means of finite elements have been presented in this paper. Initially, two elementary tee-stub connections have been proposed as benchmarks in the validation process of finite element software packages for bolted connections. Then, a rational approach that leads to an accurate simulation of these connections by means of a three-dimensional finite element model has been suggested. The model which has been set with the LAGAMINE software package has been able to reproduce many of the characteristic phenomena embodied in bolted connections. The comparison between computed and measured values in each phase has highlighted the effectiveness and degree of accuracy of the proposed finite element models. The data obtained in this study are used in [6], where a simplified three-dimensional



finite element model is set to reproduce the elastic-plastic behaviour of full bolted end plate connections by means of the ABAQUS code.

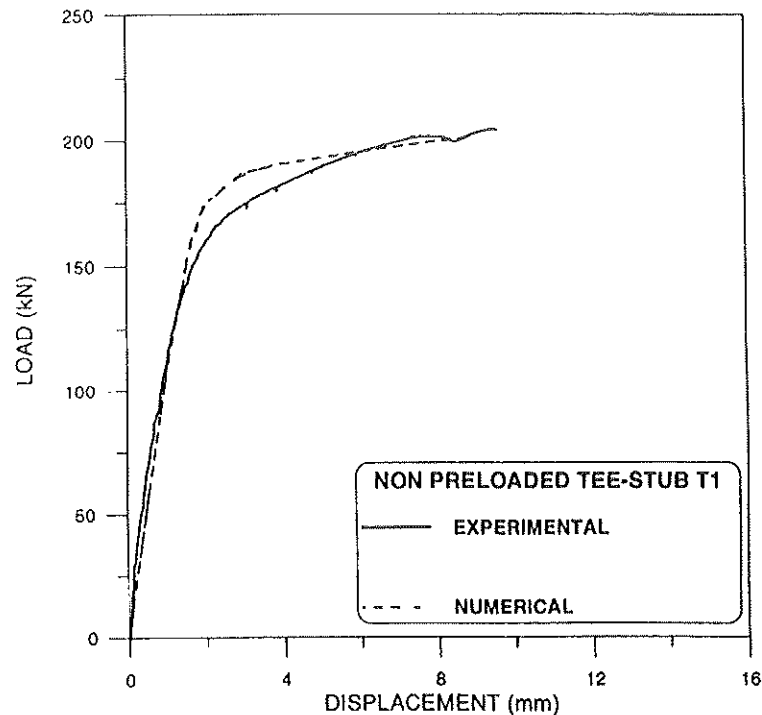

Fig. 8 Experimental and predicted relative displacement  $\Delta d$  versus load  $F$  for the non preloaded tee-stub T1

## Acknowledgements

The work reported in this paper is granted by MURST of Italy. Specific support to the University of Trento and Liège is also provided by the SPRINT Contract RA 351 financed project "Steel and Composite Building Frames using Semi-Rigid Connections: From Research to Design Practice". The findings, observations and conclusions in this paper are, however, those of the writers. The skillful work of Dominique Hanikenne, Luca Leonelli, Françoise Taquet and the technical staff of Testing Laboratories is greatly appreciated.

## References

- [1] Technical Work Group 8.2, "Analysis and Design of Steel Frames with Semi-Rigid Joints", *European Convention for Constructional Steelwork*, publication n° 67, ECCS, Brussels, (1992).
- [2] AISC, "Manual of Steel Construction - Load and Resistance Factor Design (1st edn)", *American Institute of Steel Construction*, Chicago, IL, (1986).
- [3] Eurocode 3 - ENV 1993-1-1: "Design of Steel Structures Part 1.1: General Rules and Rules for Buildings", *CEN*, Brussels, February, (1992).

- [4] Eurocode 3 - New Revised Annex J: Joints in Building Frames. *ENV 1993-1-1/pr A2*, (1994).
- [5] Cescotto S., Habraken A-M., Radu J-P and Charlier R., "Some Recent Developments in Computer Simulations of Metal Forming Processes, *Proc. 9th Int. Conf. on Computer Methods in Mechanics*, 4, Krakow-Rytro, Poland, (1989), 19-52.
- [6] Bursi O.S. and Jaspart J.P., "Calibration of a Finite Element Model for Bolted End Plate Steel Connections", *Journal of Constructional Steel Research*, (submitted).
- [7] ABAQUS - Theory Manual. Version 5.4, Hibbitt, Karlsson & Sorensen Inc. (1994).
- [8] ABAQUS - User's Manual. Vol. I & Vol II. Version 5.4, Hibbitt, Karlsson & Sorensen Inc. (1994).
- [9] Bursi O.S. and Jaspart J.P., "Benmarchs for Finite Element Modelling of Bolted Connections", *Journal of Constructional Steel Research*, (submitted).
- [10] Jaspart J.P., "Numerical Simulation of a T-stub - Experimental Data", *COST C1 Numerical Simulation Working Group*, Doc. C1WD6/94-09, (1994).
- [11] Bursi O.S., "A Refined Finite Element Model for Tee-stub Steel Connections", *COST C1 Numerical Simulation Working Group*, Doc. C1WD6/95-07, (1995).
- [12] Li, K.P., Cescotto, S., & Jetteur, P., "An Element with Hourglass Control for Large Deformation Analysis in Three Dimension", *Third Int. Conf. on Computational Plasticity: Fundamental and Applications*, Barcelona, (1992), 2021-2032.
- [13] Charlier R. and Habraken, A.M., "Numerical Modelling of Contact Phenomena by Finite Element Method", *Computers and Geotechnics*, 9, (1990), 59-72.
- [14] Li K.P., "Contribution to the Numerical Simulations of Three-Dimensional Sheet Forming by Finite Element Method", Ph.D. Thesis, Chapter 2, Dpt MSM, University of Liege, Belgium, (1996).
- [15] Agerskov, H., "High-Strength Bolted Connections Subject to Prying", *Journal of Structural Engineering Division, ASCE*, Vol. 102-1, (1976), 161-175.