

# Coupling Procedure of a Cold Rolling Lubrication Model with Finite Element Simulation of Asperity Flattening

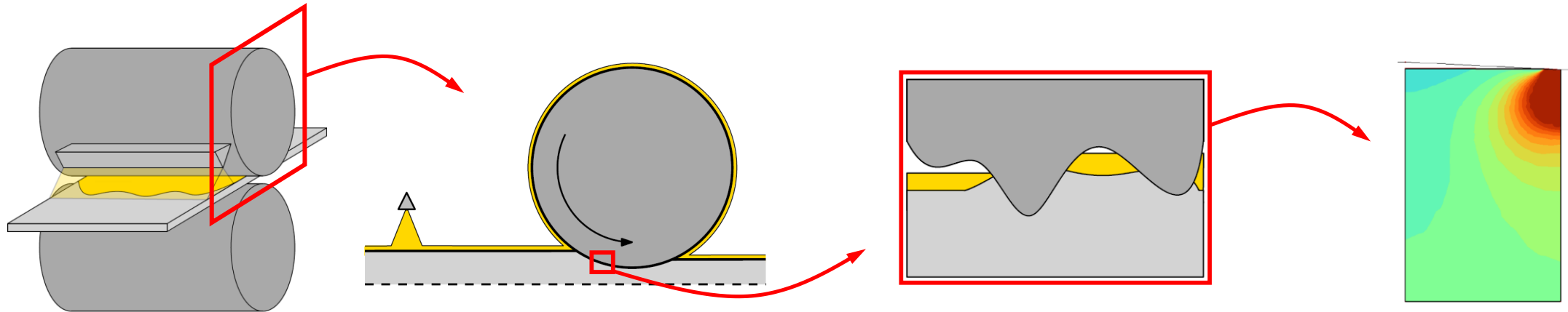

**Dominik BOEMER**, Yves CARRETTA, Romain BOMAN, Luc PAPELEUX,  
Nicolas LEGRAND, Maxime LAUGIER and Jean-Philippe PONTHOT

[dominik.boemer@uliege.be](mailto:dominik.boemer@uliege.be) – <http://metafor.ltas.ulg.ac.be>

COUPLED 2019 – Sitges, Spain – June 3<sup>rd</sup> - 5<sup>th</sup>, 2019

# Outline

---

1. Context
2. Metalub
3. Metalub – Metafor coupling
4. Conclusion

# 1. Context

## Cold rolling [Roberts, 1978]

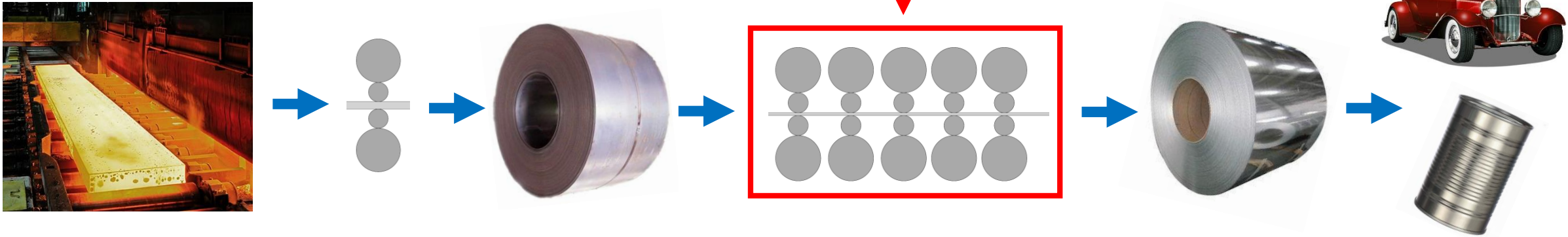

- Thickness reduction of steel strips at 25 - 150°C to satisfy strict geometrical tolerances
- Process is strongly dependent on friction created by speed difference between roll and strip
- Friction increases important process parameters like the rolling force and the forward slip

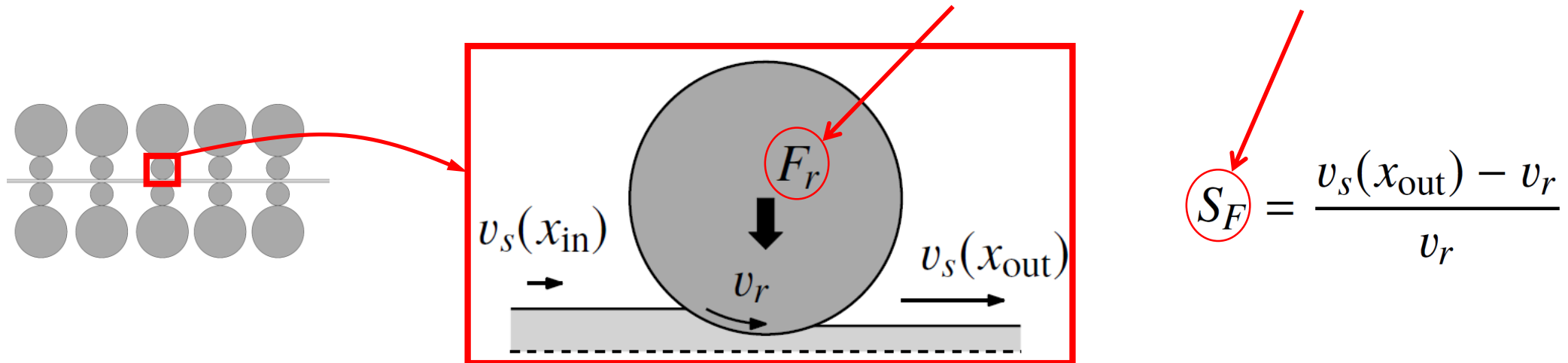

# 1. Context

## Mixed lubrication

- Challenges due to friction:
  - Mill capacity for Advanced High-Strength Steel (harder, thinner)
  - Rolling energy consumption
  - ...
- Introduction of a lubricant, and more recently, **flexible lubrication**
  - Control of friction level by adjusting oil concentration in emulsion
- Interacting **solid asperity tops** in the presence of a **lubricant**, which partially supports the load

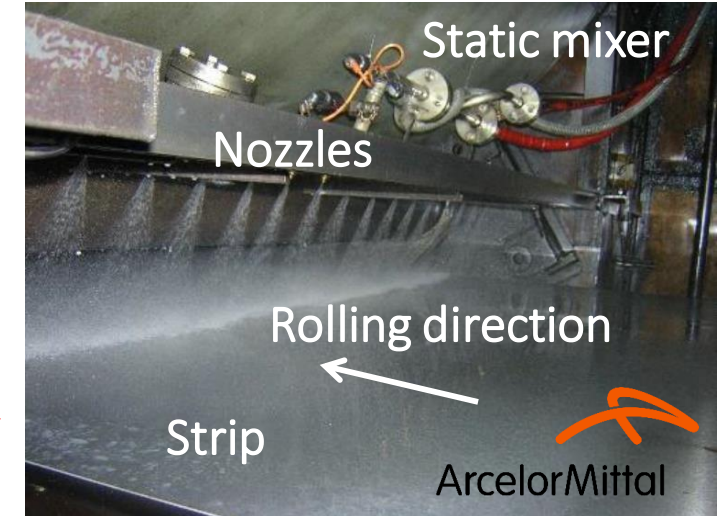

[Laugier et al., 2011]

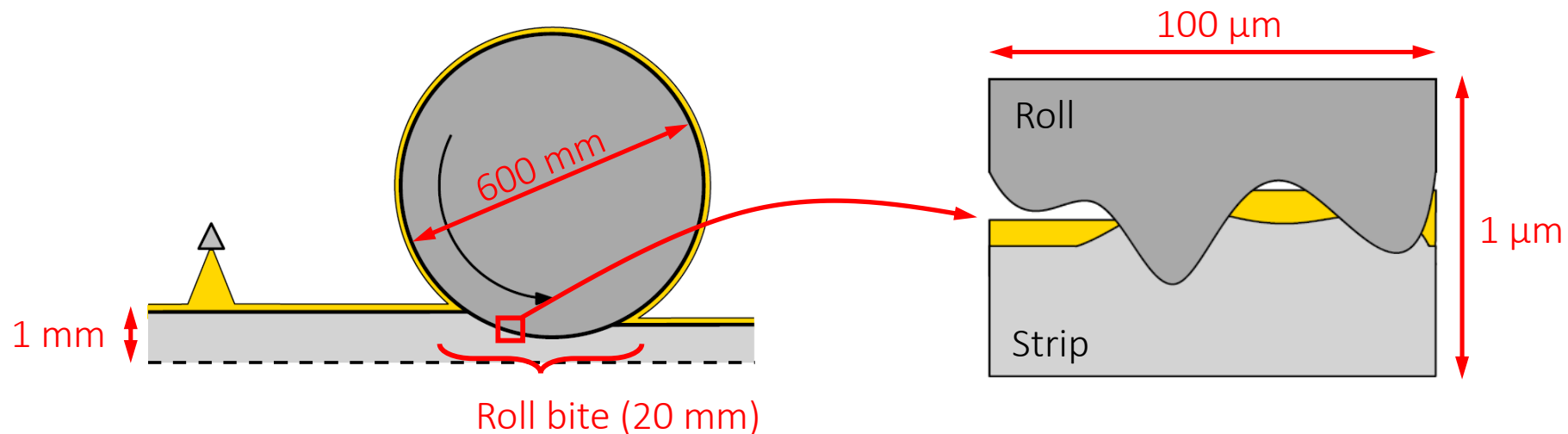

# 1. Context

## Motivation

- Predict rolling force and forward slip numerically
- To minimize friction by choosing optimal process parameters
  - Include micro-plasto-hydrodynamic and hydrostatic effects [Laugier et al., 2014] in the model

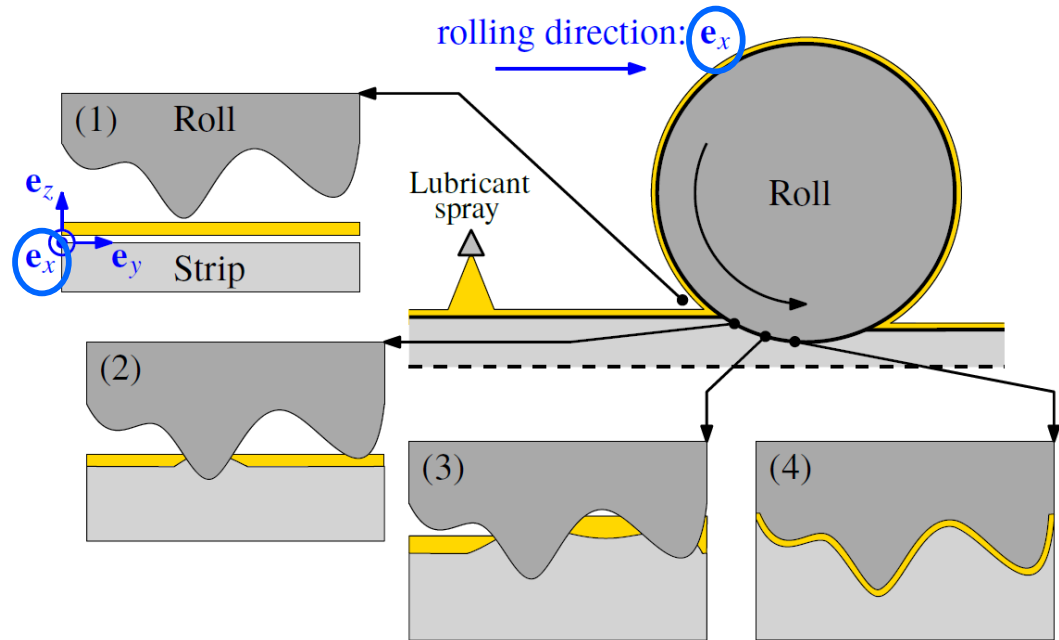
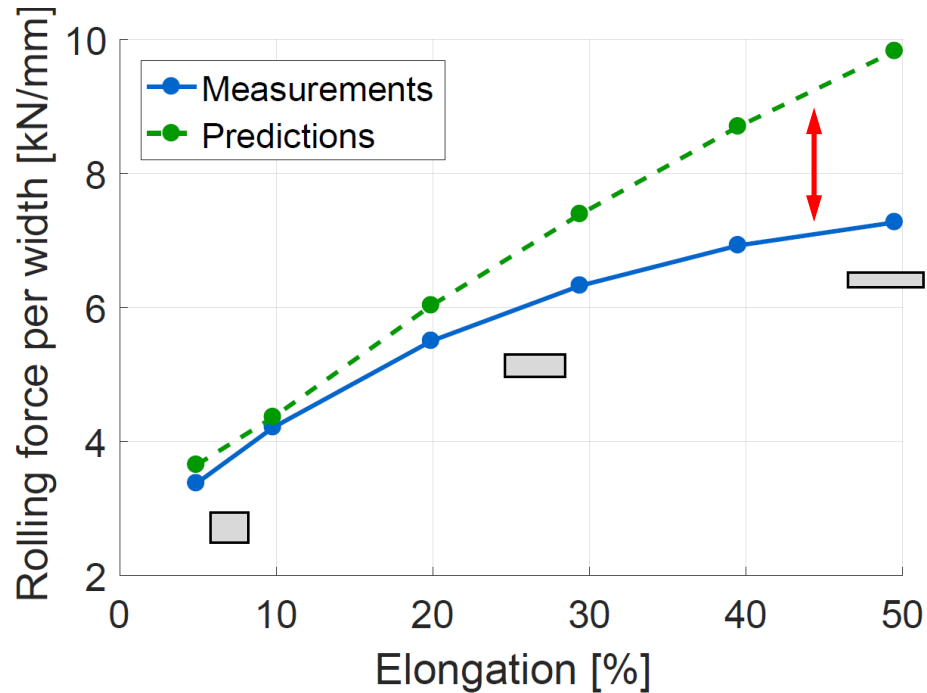

- This talk: coupling of cold rolling model with the finite element (FE) simulation of asperity flattening

# Outline

---

1. Context
2. Metalub
3. Metalub – Metafor coupling
4. Conclusion

# 2. Metalub

## Cold rolling model with mixed lubrication

- Over 20 years of development: [Marsault, 1998], [Boman et al., 2002], [Stephany, 2008], [Carretta, 2014]
- Numerous features:
  - Conservation laws: slab method, adiabatic thermal model, Reynolds equation with flow factors
  - Material laws: thermoviscoplastic (strip), thermopiezoviscous (lubricant)
  - Additional features: non-circular elastic roll flattening, lubricant starvation
  - Implemented in C++ with Python interface and GUI
- Method:

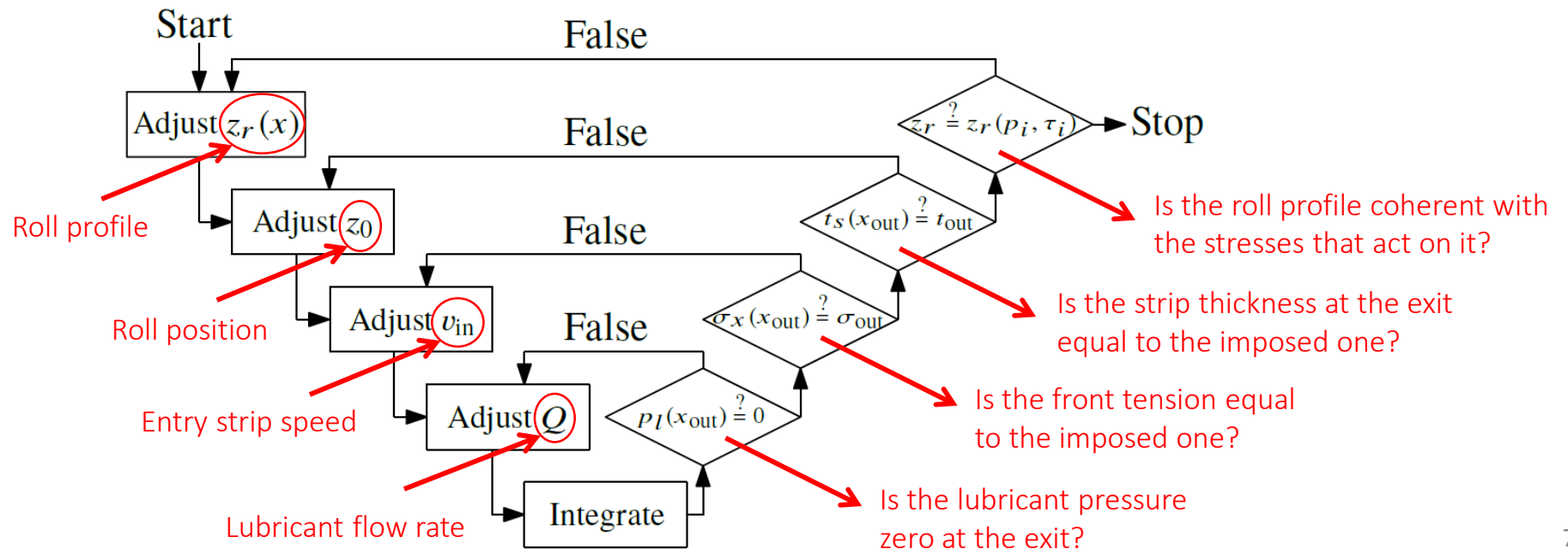

# 2. Metalub

## Numerical results

- Excellent predictions in some cases (scenario A)
- But more significant deviations in others (scenario B)
- With respect to measurements of pilot mill [Legrand et al., 2015] →



Scenario A

Scenario B

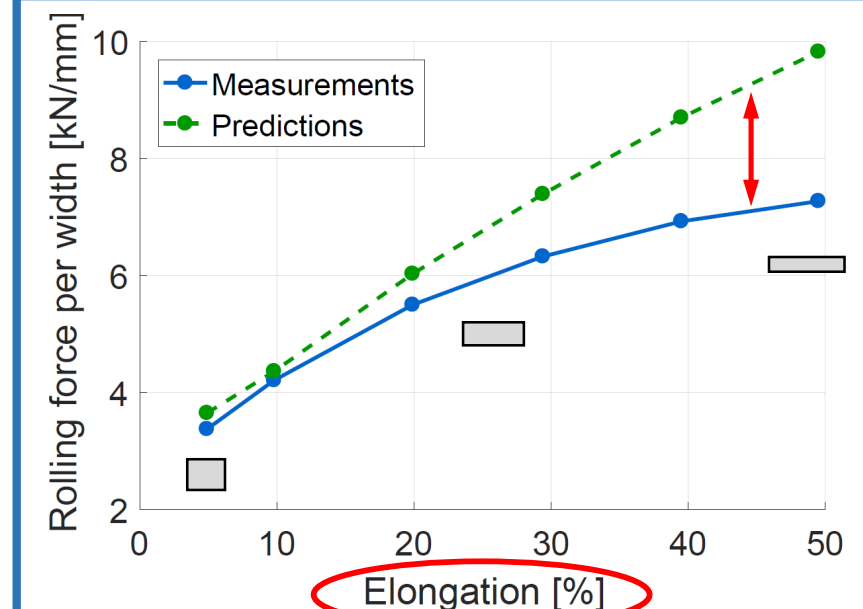
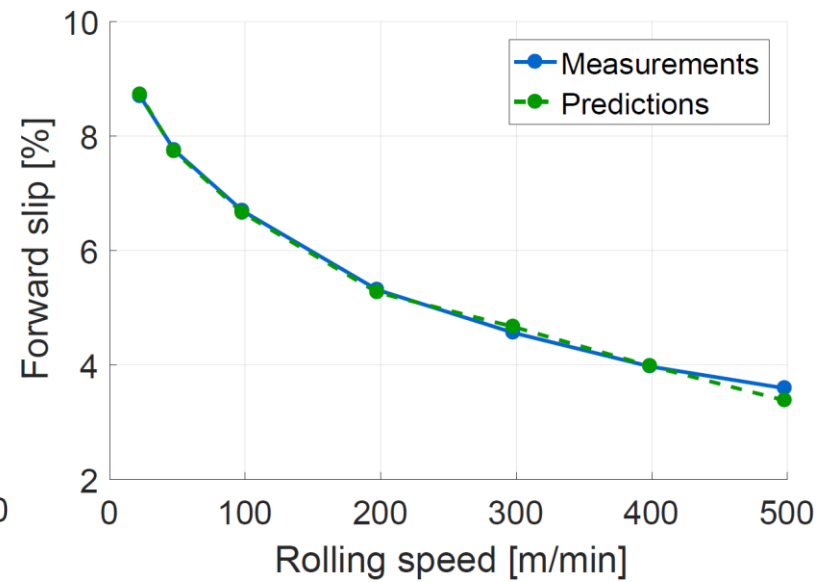
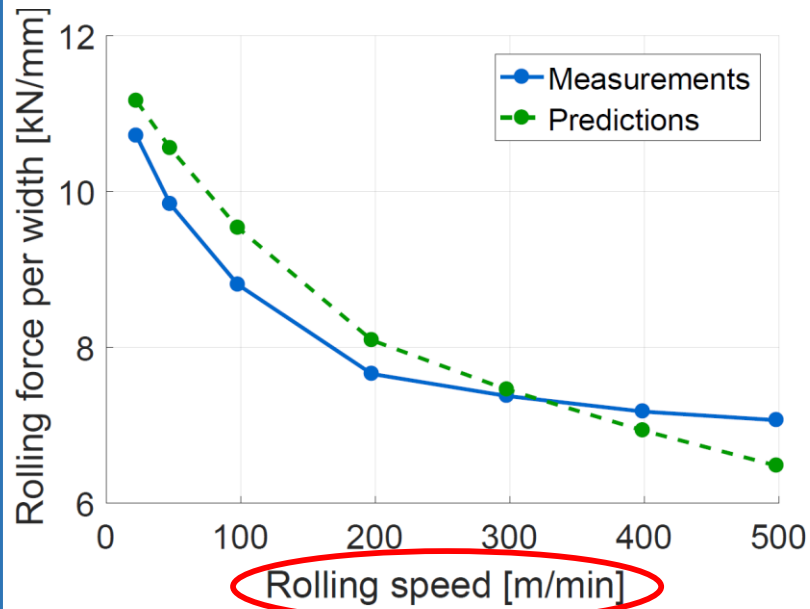





# Outline

---

1. Context
2. Metalub
3. Metalub – Metafor coupling
4. Conclusion

# 3. Metalub – Metafor coupling

## Carretta's micro-model of asperity flattening with lubricant

- Metafor: in-house non-linear implicit FE solver for large deformations
- FE asperity flattening in normal plane to the rolling direction
- Direct simulation of lubricant by Arbitrary Lagrangian Eulerian formulation
  - Problematic due to co-existence of hydrostatic and hydrodynamic models

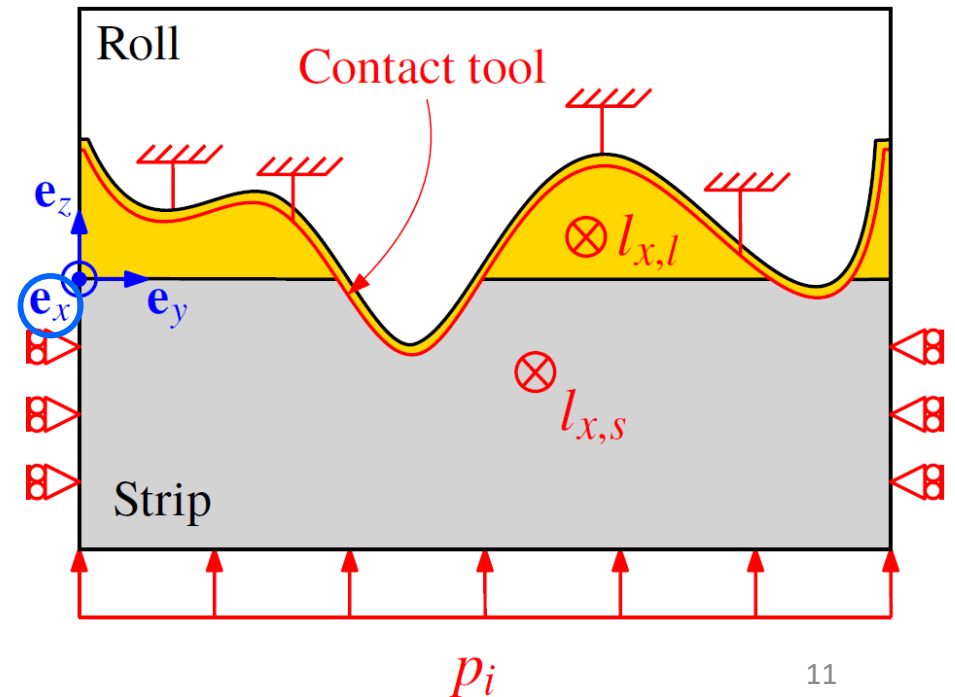
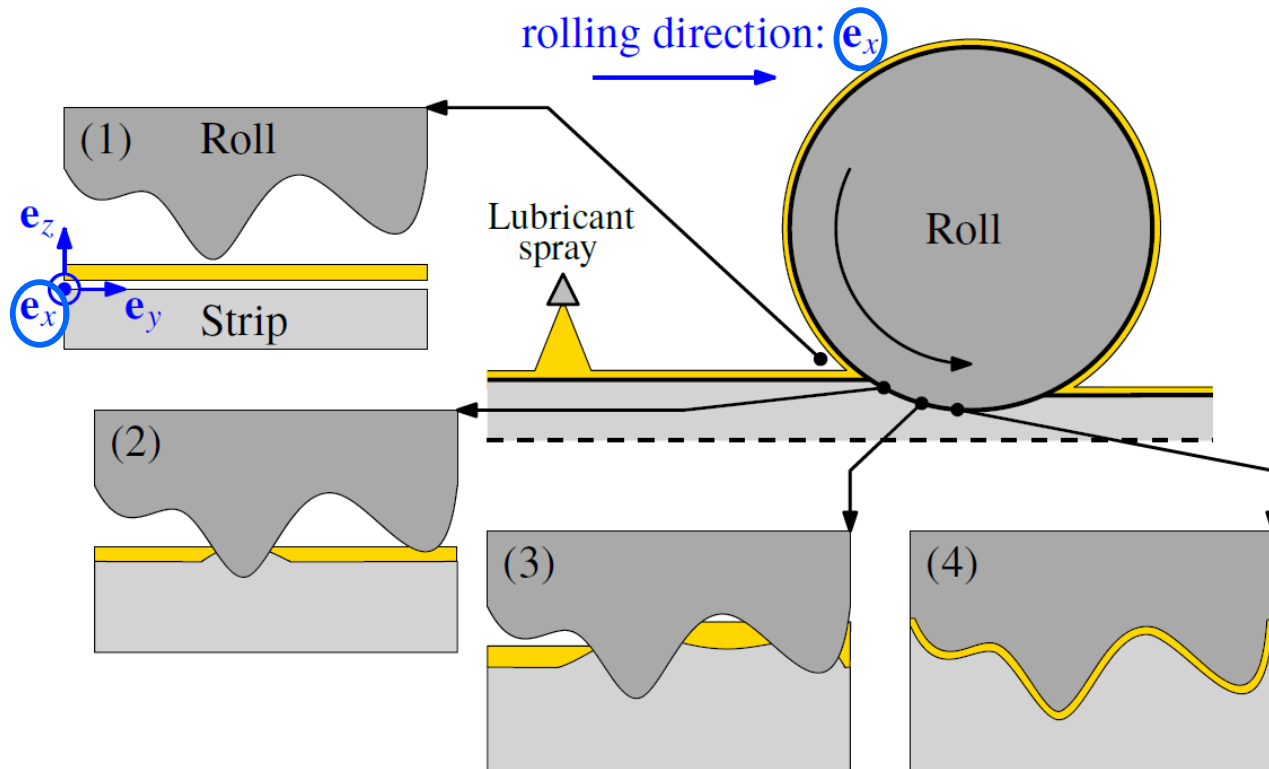

# 3. Metalub – Metafor coupling

## New micro-model of asperity flattening

- Roll modeled by rigid fixed contact tool
- Strip modeled by FEM
- Interface pressure pushes strip against roll
- Strip can not deform laterally
- Generalized plane strain state
  - Elongation of strip due to its deformation
- Lubricant pressure applied where no contact exists between roll and strip

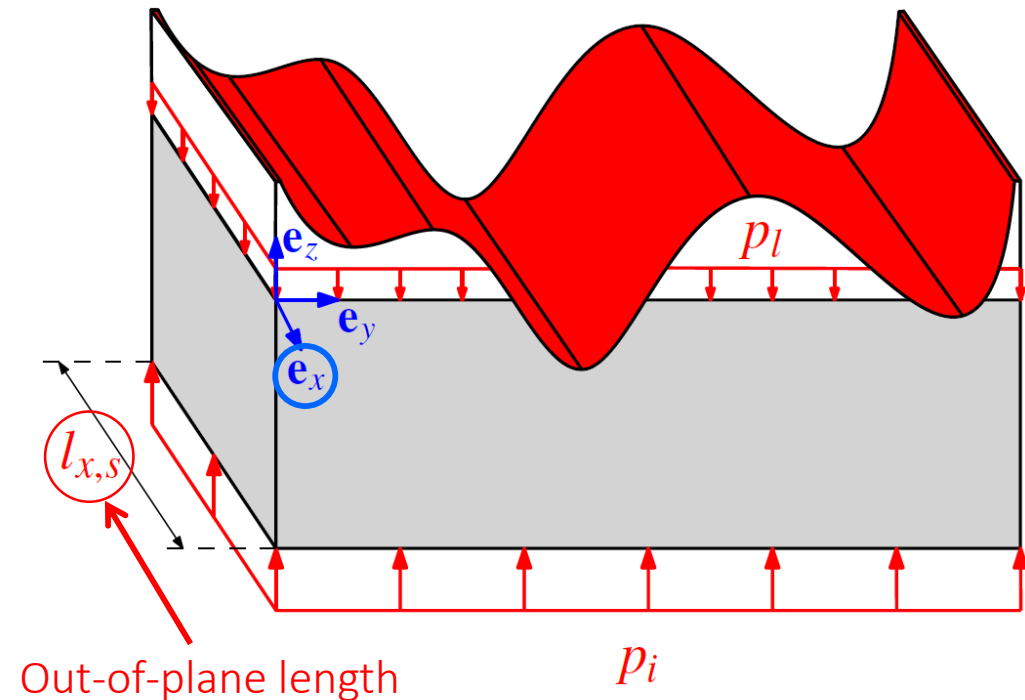
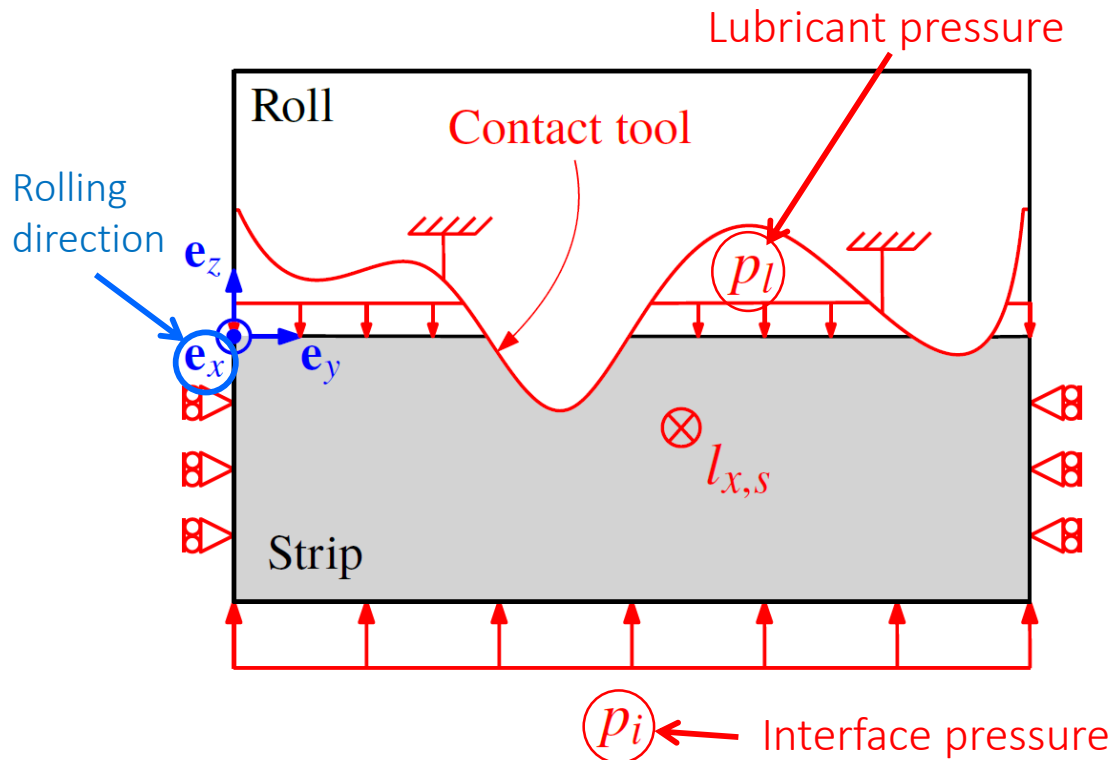

# 3. Metalub – Metafor coupling

## Full coupling procedure

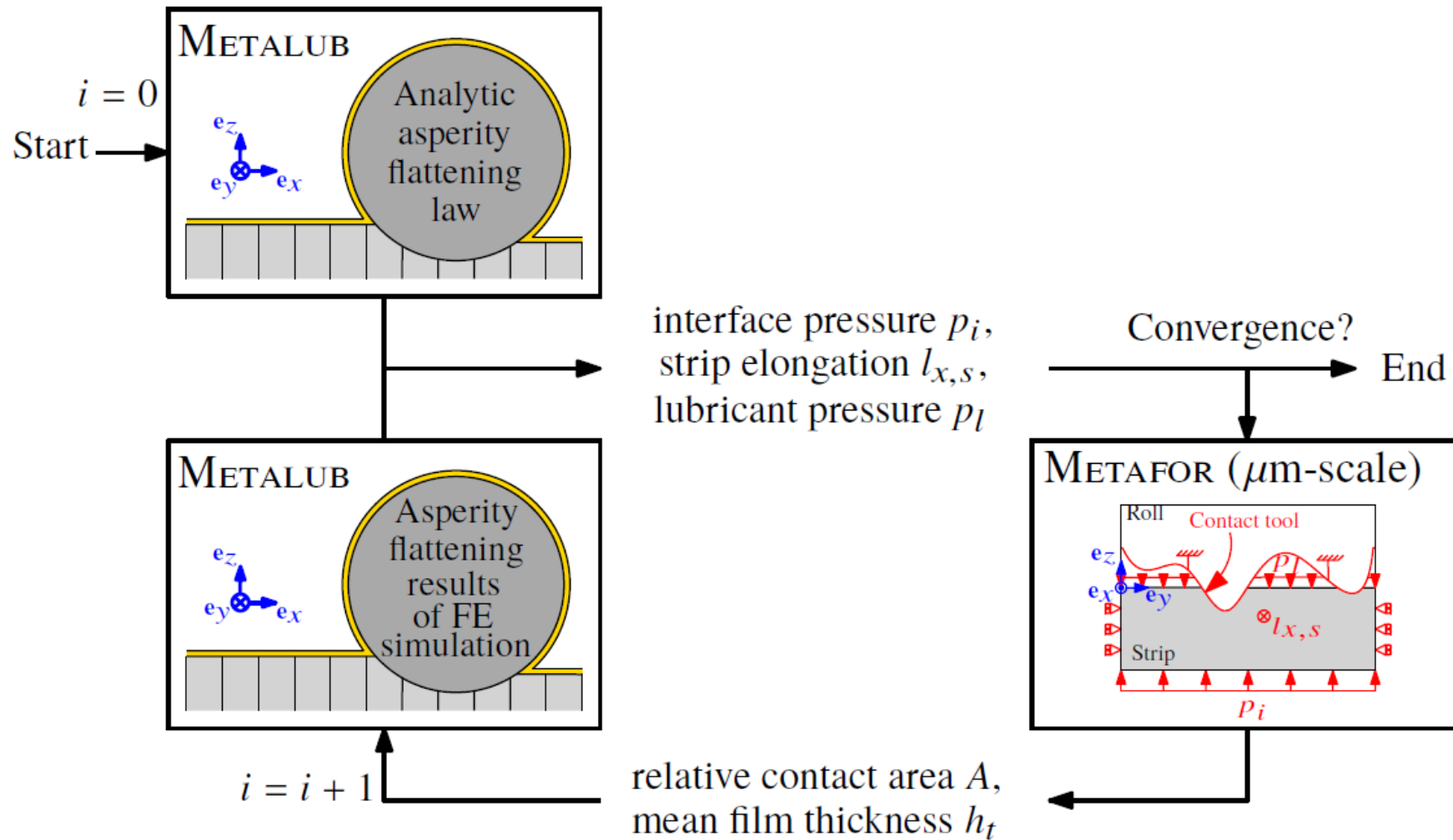

# 3. Metalub – Metafor coupling

## Numerical results (1)

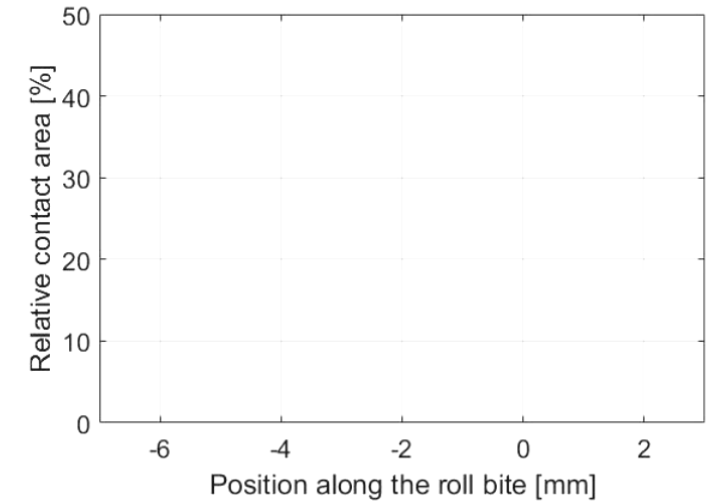
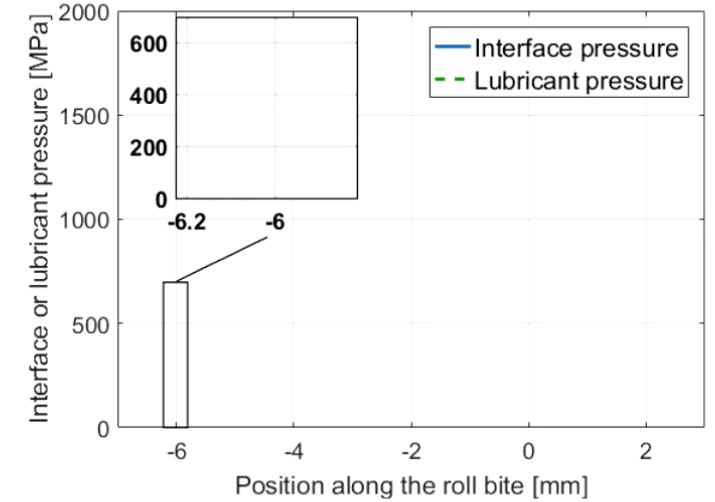
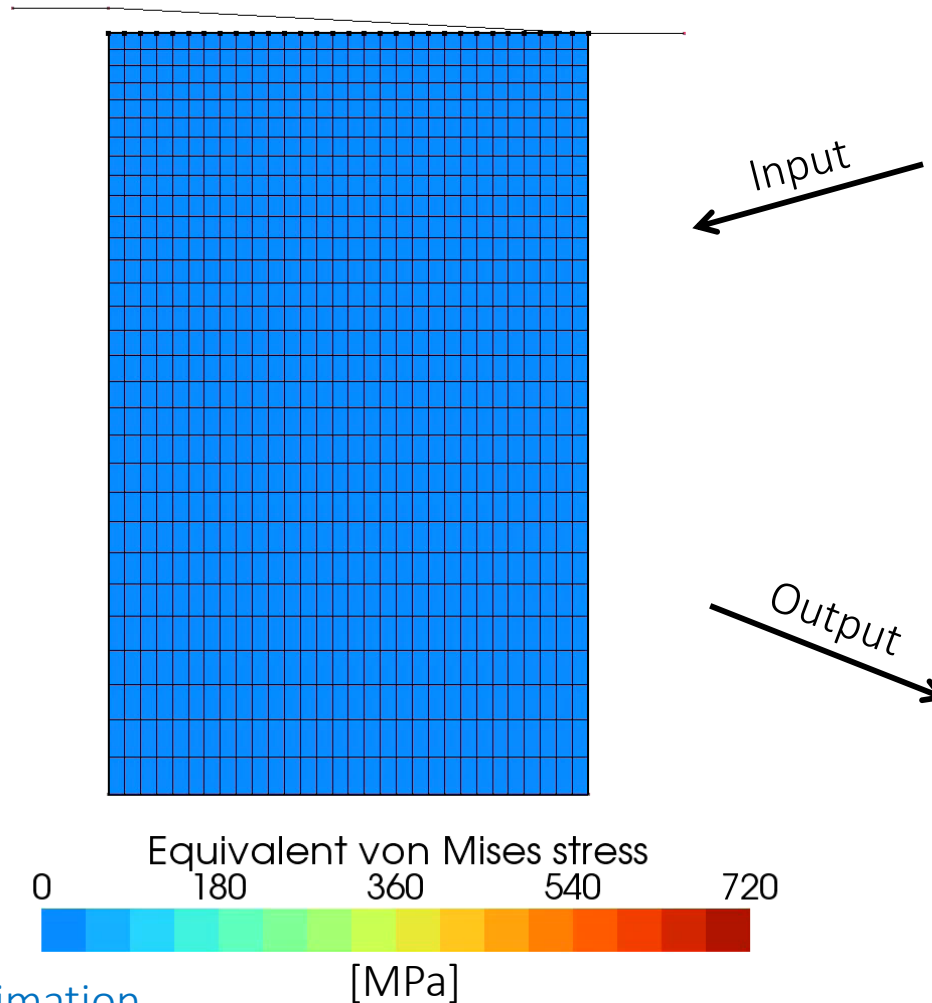
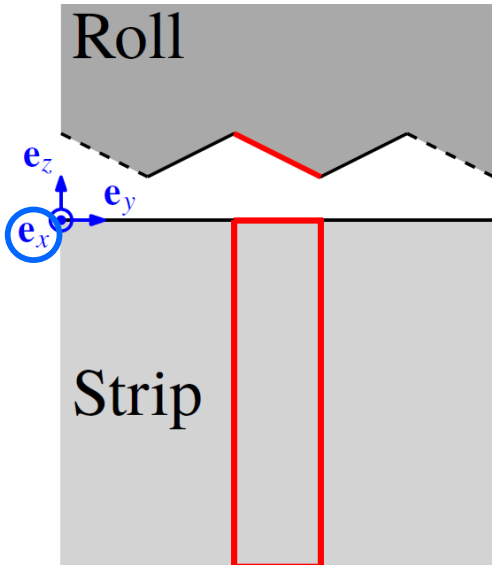

# 3. Metalub – Metafor coupling

## Shortcomings

- **Mesh-dependence** in FE model, when the lubricant pressure becomes equal to the interface pressure
  - Tentative solution: slight reduction of the lubricant pressure

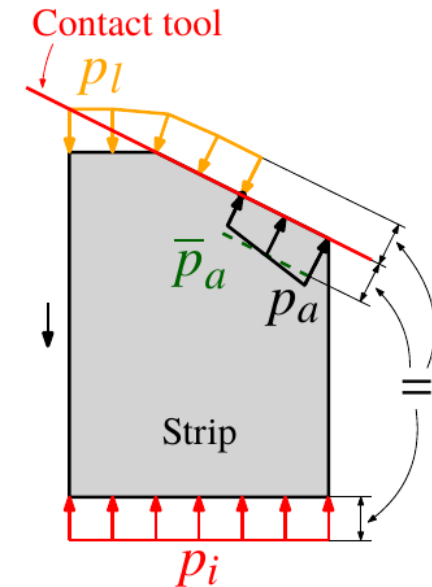
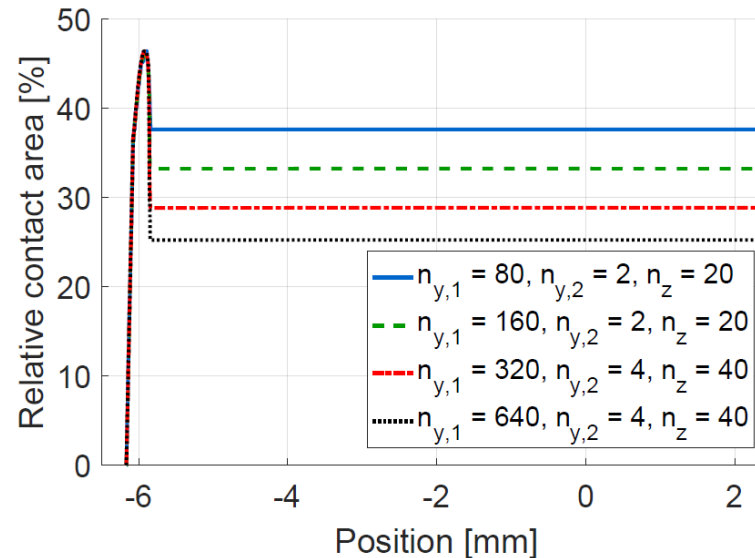
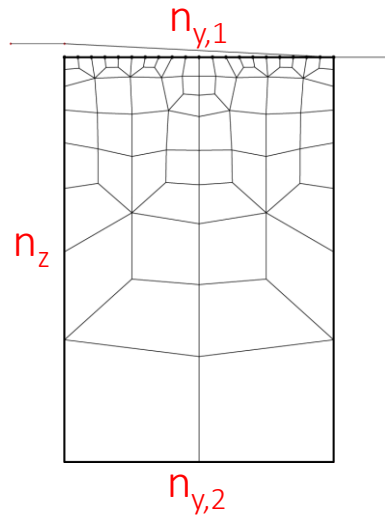

- **Insufficient strength/tightness** of the coupling
  - Tentative solution: different criterion in adjustment loop of the lubricant flow rate

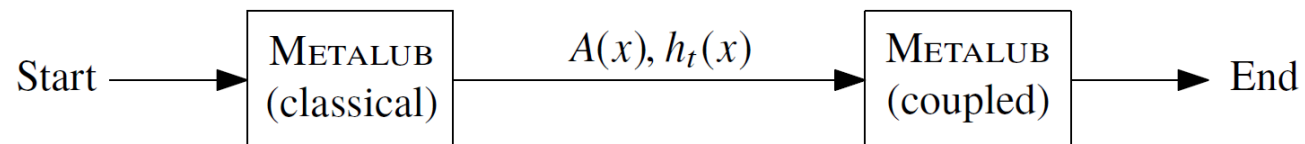

# 3. Metalub – Metafor coupling

## Numerical results (2)

- Procedure **converges** but this required relatively strong hypotheses
- **Wilson & Sheu's law** seems to overestimates the relative contact area

Convergence history

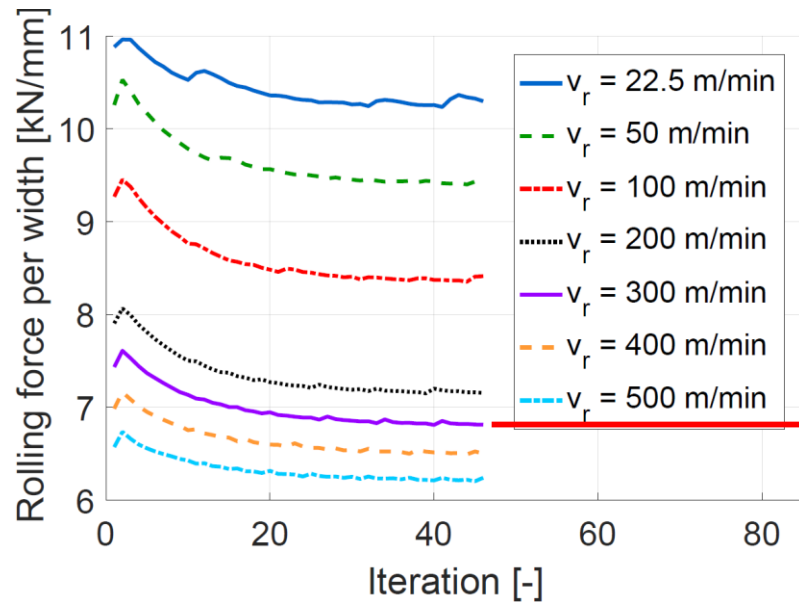

Comparison with experimental data and classical Metalub results

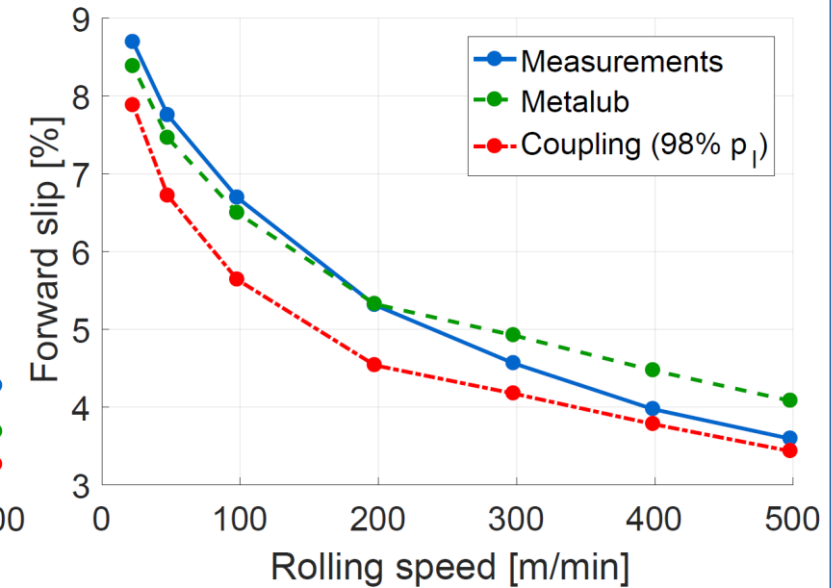
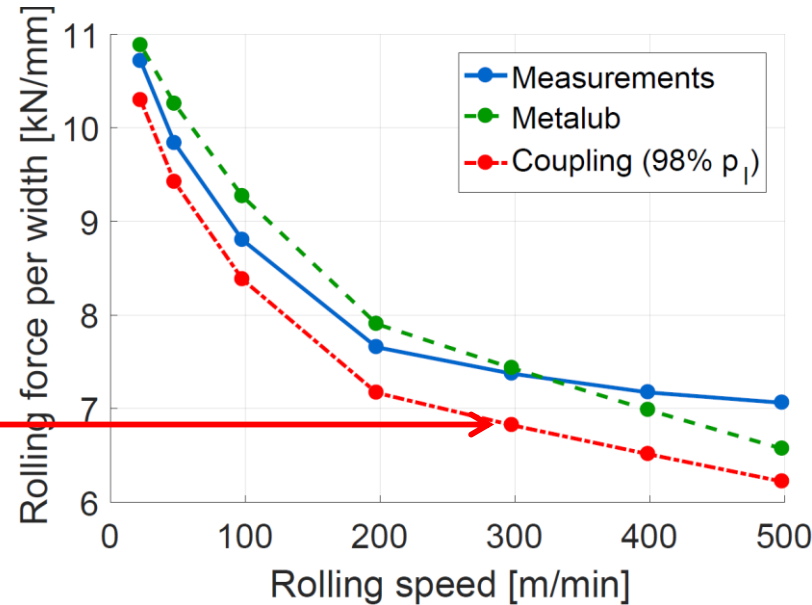



# Outline

---

1. Context
2. Metalub
3. Metalub – Metafor coupling
4. Conclusion

# 4. Conclusion

## This presentation

- Coupling procedure of [Metalub and Metafor](#)
- Analytic [asperity flattening](#) equation replaced by [FE model](#): no oversimplified geometry, material, method
- [Results](#): similar to classical Metalub model but Wilson & Sheu seem to overestimate the real contact area
- [Limitations](#): strength of the coupling, identity of lubricant and interface pressure

## Future research

- Focus on [micro-plasto-hydrodynamic and hydrostatic effects](#)
- [Smoothed particle hydrodynamics \(SPH\)](#)

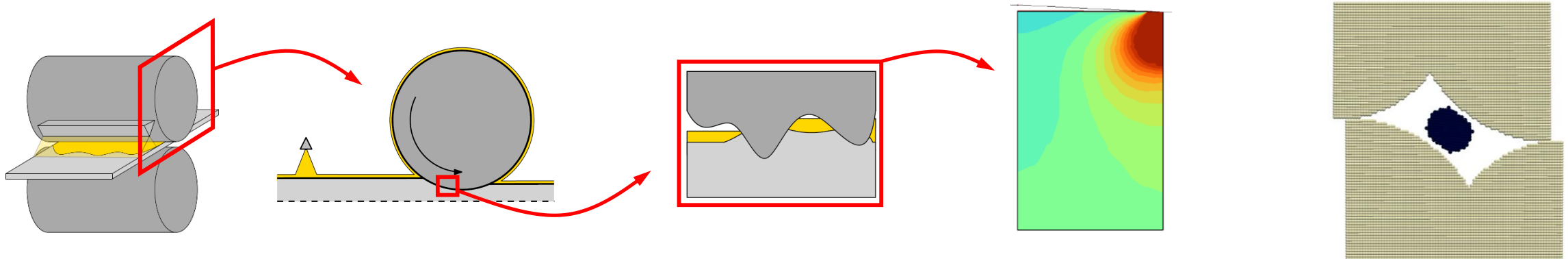

# References

- Boman, R. and Ponthot, J.-P. (2002). Numerical simulation of lubricated contact in rolling processes. *Journal of Material Processing Technology*, 125-126: 405-411.
- Carretta, Y. (2014). Modélisation des conditions d'apparition du micro-hydrodynamisme via la méthode des éléments finis dans la perspective d'intégrer ce phénomène dans un modèle numérique de laminage à froid. PhD thesis, Université de Liège, In French.
- Korzekwa, D. A., Dawson P. R. and Wilson, W. R. D. (1992). Surface asperity deformation during sheet forming. *International Journal of Mechanical Sciences*, 34(1): 521-539.
- Laugier, M., Tornicelli, M., Leligois, C. S., Bouquegneau, D., Launet, D., and Alvarez, J. A. (2011). Flexible lubrication concept. The future of cold rolling lubrication. *Proceedings of the Institution of Mechanical Engineers, Part J: Journal of Engineering Tribology*, 225(9): 949-958.
- Laugier, M., Boman, R., Legrand, N., Ponthot J.-P., Tornicelli, M., and Bech, J. I. (2014). Micro-plasto-hydrodynamic lubrication. A fundamental mechanism in cold rolling. *Advanced Material Research*, 966-967: 228-241.
- Legrand, N., Patrault, D., Labbe, N., Gade, D., Piesak, D., Jonsson, N. G., Nilsson, A., Horsky, J., Luks, T., Montmitonnet, P., Canivenc, R., Joyce, R. D., Hunter, A., Pinna, C. and Maurin, L. (2015). Advanced roll gap sensors for enhanced hot and cold rolling processes (rollgap sensors). Technical report. Research Fund for Coal and Steel, European Commission.
- Marsault, N. (1998). Modélisation du régime de lubrification mixte en laminage à froid. PhD thesis, Ecole Nationale Supérieure des Mines de Paris. In French.
- Roberts, W. L. (1978). *Cold rolling of steel*. Marcel Dekker, New York.
- Stephany, A. (2008). Contribution à l'étude numérique de la lubrification en régime mixte en laminage à froid. PhD thesis, Université de Liège. In French.
- Wilson, W. R. D. and Sheu, S. (1988). Real area of contact and boundary friction in metal forming. *International Journal of Mechanical Sciences*, 30(7): 475-489.

# Acknowledgment

---

The first author, Dominik Boemer, would like to acknowledge the Belgian National Fund for Scientific Research (F.R.S.-FNRS) for its financial support (F.R.S.-FNRS Research Fellowship).

