

Volition and the Theory of Planned Behaviour: How to Fill the Gap between Intention and Performance?

Jean-Paul Broonen

*Service d'Orientation Universitaire, Université de Liège
Traverse de Architectes – B3g3, 4000 Liège1, Belgium, JP.Broonen@ulg.ac.be*

Abstract. This study evaluated the contribution of implementation intentions over the constructs of the theory of planned behaviour in testing a confirmatory model explaining the relationships between antecedents of academic achievement for university students. It was found that the effects of intention to perform and its classic antecedents on exams performance were mediated by implementation intentions with a considerable increase of amount of explained variance above the contribution of the constructs of planned behaviour theory. This paper is organized as follows. We first introduce the construct of intention, particularly in the context of the well documented model of the theory of planned behaviour (TPB). The limitation of this model will be explained and a basic distinction it does not consider will be pointed to: forming an intention vs. implementing it. Then we present the Heckhausen and Gollwitzer's Action Phases Model (APM) and the construct of implementation intention. The results of experimental and correlational researches on the predictive power of this construct, especially in the educational domain, will be discussed. Thirdly, we propose an integrative model which fills the gap between TPB and performance by introducing implementation intentions from unwanted inner states. Fourthly, we give the results of an experimental research aiming in testing this model conducted in an educational settings and using a confirmatory design (Structural Equation Modelling). In the end, we insist on the implication of these results for students.

Keywords: implementation intention, motivation, volition, planned behaviour theory, college performance

PACS: 02.30.Yy, 01.40.gb

1. INTRODUCTION

Goal theories all converge on the idea that intention is the key determinant of behaviour (see for summaries Abraham, Sheeran, & Johnston [1]; Austin & Vancouver [2]; Eagly & Chaiken [3]; Gollwitzer & Moskowitz [4]). Intentions were defined by Triandis [5] as self-instructions to perform particular behaviours or to obtain certain outcomes. They are usually measured by endorsement of items such as 'I have the intention to do *X*'. In classical theories of goal striving, forming a behavioural or goal intention signals the end of the mental act of deliberation about what one will do and is referred to "a person's subjective probability that he will perform some behaviour" (Fishbein & Ajzen [6], p. 288) or is an indication "of how hard people are willing to try, or how much of an effort they are planning to exert, in order to perform the behaviour" (Ajzen [7], p. 181)

Thus, intention is the decision to act in a particular way and represents a person's *motivation* in the sense of her or his decision to exert effort in order to achieve desired outcomes.

In the TPB (Ajzen [8], [7]; Ajzen & Madden [9]), an expectancy-value model of attitude-behaviour relationships, intention is the proximal determinant of behaviour and mediates the influence of the theory's predictors, namely attitude, subjective norm, perceived behavioural control, and external variables (e.g., personality and demographic characteristics).

The attitude toward the behaviour refers to the degree to which a person has a favorable or unfavorable evaluation of the target behaviour. Broadly speaking, it is the extent to which the person considers the behaviour to perform as a favorable or an unfavorable thing. Subjective norm refers to the perceived social pressure to perform or not the behaviour. This variable is a more social account of the kinds of beliefs that have consequences on behaviour. Finally, the behavioural intention can find expression in behaviour only if the person can decide at will to perform or not the behaviour in question. Although some behaviours may meet this requirement, the performance of

most depends at least to some degree on non-motivational factors such as abilities or availability of requisite opportunities and resources.

As a consequence, Ajzen [8] introduced a third variable, the perceived behavioural control (PBC), he presents as most compatible with Bandura's [10] concept of perceived self-efficacy. A measure of PBC ought to capture people's confidence that they are capable of performing the behaviour under investigation. The predictive power of PBC is assumed to act through intention or directly on behaviour. The complete model¹ can be written as follows:

$$B \approx I (w_1 A_B + w_2 SN + w_3 PBC)$$

where B = behaviour, I = behavioural intention, A = attitude, SN = subjective norm, and PBC = perceived behavioural control. The approximate sign \approx indicates that a measure of intention is expected to predict behaviour only if intention have not changed as a result of influencing events. The w_n are empirically determined weights.

Meta-analytic reviews indicate that attitudes, subjective norm, and PBC account for substantial variance in intentions (Ajzen [7]; Armitage & Conner [11]; Godin & Kok [12]; Sutton [13]). But the prediction of behaviour is less impressive. In general - i.e., non only considering the TPB, but also other theories of intention such as the theory of reasoned action (Fishbein [14]; Fishbein & Ajzen [6]) or the protection motivation theory (Floyd, Prentice-Dunn, & Rogers [15]) -, meta-analyses of correlational studies showed that intention typically explains 28 % of the variance in goal achievement (Sheeran [16]), which is a "large" effect size (Cohen [17]). However, past behaviour is also a good predictor of future behaviour (see Sutton and Sheeran's meta-analysis, 2003, quoted by Gollwitzer and Sheeran [18]): the effect size for goal intentions when controlling for this variable is only small-to-medium (rather than large) effect size. Moreover, experimental studies (Webb & Sheeran [19]) showed that producing significant changes in goal intention strength generates only a modest change in goal achievement. This finding indicates that there is a substantial gap between people's goal intention and their subsequent attainment.

In the academic performance domain, predictive research using the TPB model pertains to learning behaviours, and, much more scarcely, to exams performance.

Sideridis, Kaissidis, and Padelidiu [20] provided a structural equation modeling model where TPB predicted student study behaviour (but without mentioning the amount of explained variance). However, in a subsequent research, Sideridis and Kaissidis-Rodafinos [21] failed to adequately explain study behaviour. Perugini and Bagozzi [22] deepened the TPB by introduction of extra-constructs (desires, past study behaviour): 24 % of effort behaviour by university students were explained against 15% for the original TPB. An other augmented TPB (Leone, Perugini, & Ercolani [23]) by impacting past habits of study variables directly on intention and study behaviour brought a gain of 15% in explained variance of behaviour ($R^2 = .47$).

In the exam marks domain, Ajzen and Madden [9] predicted getting an 'A' as behavioural goal in a course of psychology. With respect to the prediction of intention, the multiple correlations between intention and the target behaviour were .64. With respect to the prediction of behaviour, the multiple correlations were .45. Phillips, Abraham, and Bond [24] using a structural equation modeling found that the TPB augmented by the Big Five, intrinsic/extrinsic motivation, anticipated regret, and identity explained 32% of the variance of undergraduate students' final degree marks.

In sum, even deepening the TPB with addition of other variables does not prevent the intention-behaviour relation from remaining relatively weak largely due to the fact that people have good intentions but often fail to act on them (Orbell & Sheeran, quoted by Gollwitzer and Sheeran [18]). Accordingly some authors caring about action control have called for greater attention to the distinction between *forming* a decision (an intention), primarily a motivational process, and *implementing* it, a volitional process (Kuhl, [25], [26]; Zhu [27]; Kuhl & Beckmann [28]). A goal intention, defined as intention to reach desired end states (format: 'I intend to reach x ', x specifying the goal), turns a desire (e.g., 'I want to be successful in exams') into binding goal (with a feeling of determination to fulfill the implied wish) ('I intend to be successful in exams'). Implementing intentions means following through one's intentions. Volition addresses the regulation of behaviour and environment after the intention has been formed. Recent research on goal-directed behaviours have demonstrated that variables other than strength of goal intention affect the intensity of goal striving and rate of goal attainment (Gollwitzer & Moskowitz [4]; Oettingen & Gollwitzer [29]).

Problems of goal implementation can be classified into two categories (Gollwitzer & Oettingen [30]). The first set of problems involves action initiation. For various reasons, people do not avail themselves of the opportunities to act and as a consequence delay goal attainment. The second series of problems includes making sure that, once started,

¹ This original simple linear model postulates no interaction between determinants of intention. Several studies report however significant correlations for instance between attitude and subjective norm. In the formulation of the TPB, Ajzen [7] explicitly postulates relations among focal variables of the model.

goal pursuit is effectively completed. People often renounce in the face of external difficulties or fail to protect against distractions or are faced to inner obstacles, and have trouble restarting goal pursuit once interruptions have occurred.

Therefore, some scholars assumed that setting an intention is only the first step to goal realization. Outside the field of the TPB, Gollwitzer [31] and Heckhausen (Heckhausen [32]; Heckhausen & Gollwitzer [33]) proposed a model of action phases (APM) which suggests that adopting a behaviour has two distinct stages. The first one is a motivational or deliberative phase during which the individual weighs up the costs and benefits of performing the behaviour. This phase culminates at the transition decision point with the development of a behavioural intention (Crossing the Rubicone metaphor). This phase parallels the view of intention formation offered by the TPB. But unlike the TPB, “the model [of action phases] states that goal attainment is not yet secured by the act of goal setting (i.e., having formed more or less strong goal intention)” (Gollwitzer & Sheeran [18], p. 74). This model meets Kuhl's [34] argument: “a person can believe in his or her self-efficacy or can be highly motivated and still might not be able to enact intentions he or she is committed to if self-regulatory abilities are insufficient” (p. 114). Forming an intention is particularly not a sufficient condition for initiating or completing effective actions that have not become transformed in routines in stable situational contexts. The necessity of self-regulatory processes mediating the effects of intention on behaviour is implied by unfamiliarity with the respective goal-directed actions and context of performance or by impossibility of immediate realization of goal intentions: unavailability of relevant opportunities to act or shifting of the person's attention because she is captivated by a more attractive competing goal pursuit, etc. Students entering the university have obviously to confront unusual situation: since academic tasks extend over several weeks and months, something else than simply desiring to obtain good marks has to come into play to help shielding intention to learn and to attain success from distractions, temptations, and dismissing effort (Broonen [35]). Regulation of the actual striving for the goal (i.e., engaging in effective goal implementation) is a requisite for academic success.

Therefore, the APM posits a post-intentional or volitional phase (pre-actional phase) during which the individuals have to develop strategies and plans for getting started and to protect ongoing goal striving from getting derailed (Gollwitzer, Bayer, & McCulloch [36]). This suggests that a motivational model such as TPB could fruitfully be supplemented by volitional strategies to increase the likelihood of performing.

A volitional strategy that has received empirical support over recent years is the construct of implementation intention (IMI) (Gollwitzer [37], [38], [39]; Gollwitzer & Brandstätter [40]). The initiation of difficult goal-directed actions needs to be prepared by the self-regulatory tool of conscious IMIs, i.e., plans that specify an anticipated cue as a condition for initiating goal-directed behaviours: a good opportunity to act is selected in the *if* (or *when*)-component and an appropriate instrumental goal-directed response in the *then*-component of an *if-then* plan (‘If I encounter situation *Y*, then I will initiate goal-directed behaviour *X*’), which spells out when, where and how to implement goal-directed behaviours (e.g., ‘When it's 8 o'clock to-morrow, I'll sit down at my desk and study my physics, chapter 3, during 1 hour’). By forming an IMI a mental link is created between a specific future situation and the intended goal-directed behaviour which facilitates the mental representation of the specified cue. The latter becomes highly activated and therefore more easily accessible when the critical cue is encountered, which facilitates its detection. Moreover, when the specific conditions are met, the environmental cues stimulate automatic activation of behaviour without further conscious intent (Orbell, Hodgkins, & Sheeran [41]; Sheeran & Orbell [42]). IMIs delegate control of behaviour to the specified environmental cues.

In health domain, goal intentions in a TPB supplemented by IMIs were proved to more likely be enacted (Orbell *et al.* [41]). In protecting ongoing goal striving from getting derailed, IMIs lead to more frequent goal attainment compared to setting mere goal intentions (review by Gollwitzer & Sheeran [18]).

In the academic domain, Bayer and Gollwitzer [43] observed that high school students with self-efficacy strengthening IMIs outperformed the mere achievement goal intention participants in mathematic tests or in analytic reasoning test. Interestingly, Achtziger, Gollwitzer, and Sheeran [44] tested successfully whether IMIs could be used when shielding ongoing goal pursuits from disruptive inner states is necessary. People that can exploit inner states as initiators of goal-shielding responses have at their disposal a self-regulating strategy usable across all types of goal strivings as well as various disruptive contexts.

Past research on IMIs observed the automation of the initiation of the action specified in the *then*-component without further conscious intent (e.g., Brandstätter, Lengfelder, & Gollwitzer [45]; Gollwitzer & Brandstätter [40]). Accordingly, the detrimental inner states as *if*-components in IMIs are supposed to lead to a faster detection of these specified inner states compared to other inner states.

IMIs are typically what Dubois [46] called endo-anticipation: the individual system builds a discursive anticipation about a specific future inner state that is cognitively bounded to a future behaviour and situational cues.

The present research tested a general model where IMIs geared at controlling potentially interfering motivational inner states were integrated in a particular expectancy-value model, namely the TPB. It was hypothesized that these IMIs would mediate the effects of the TPB classical variables to impact through self-regulative actions on final exam marks with an increase of amount of explained variance of performance above the contribution of the constructs of TPB.

2. AIM AND HYPOTHESES OF THE RESEARCH

The theoretical literature reviewed so far suggests the need to test the sufficiency of the TPB in academic performance domain in focusing on volitions in order to improve the prediction of final degree marks. Therefore three hypotheses were tested:

- H1. IMIs geared at controlling potentially interfering motivational inner states with study behaviours would enhance the rate of corresponding control actions specified in the *then*-component.
- H2. The effects of the TPB variables on performance would be mediated by volitional variables.
- H3. The mediation of TPB by volitional variables would enhance the amount of explained variance of final marks.

3. METHOD

3.1 Participants and Procedure

Two hundred and seven freshmen (163 females; *M* age 19.3 yrs; *SD* = 1.9) took part in the study for extra credit in their introductory psychology courses. Informed consent was obtained from participants who attended large group sessions before exams at two times (three months interval between control actions and the other antecedent predictive variables).

3.2 Instruments

Participants completed a questionnaire that asked them to specify the following variables.

Attitude toward number of exams intended to pass was measured using six adjective items (disturbing-reassuring, motivating-demotivating, useful-useless, positive-negative, essential-subordinate, satisfying-unsatisfying) on a 7-point bipolar scale. The stem that preceded the adjectives was 'For me to be successful on exams would be . . .'. Two random aggregates of three items each were created (Bagozzi & Heatherton [47]).

Subjective norm was measured by a single item on a 7-point scale that ranged from 1 (strongly disagree) to 7 (strongly agree): 'Most people who are important to me think that I should pass the exams I intend to pass'. In a preliminary analysis, this variable was proved to be unrelated to intention to pass exams and eliminated from the model. This result was not unexpected (Ajzen & Madden [9]).

Perceived behavioural control was measured on a 7-point scale (1 – 7; *strongly disagree–strongly agree*) by three items (e.g., 'Passing exams depends only on me').

Self-efficacy was measured by a single item (7-point scale; *not at all confident–definitely confident*): 'How much confident are you that you have personal resources to pass your exams?'

Goal intention was measured by the statement 'I intend to pass 1 vs. 2 vs. 3 vs. 4 vs. 5 exams'.

IMIs were measured by two items (7-point scale; *strongly disagree–strongly agree*). For example, one item was 'If studying becomes boring, I intend to look for good reasons to proceed'.

Control actions were measured by the two verbatim statements of the IMIs *then*-component.

Performance was assessed by mean final degree marks.

3.3 Method of Measurement

Structural Equation Modeling (SEM) was used to test the discriminant validity between the constructs and to submit the models to a confirmatory analysis. As data were continuous and did not follow a multivariate normal distribution, the *Robust Maximum Likelihood Method* (Boomsma & Hoogland [48]) was used. This method requires an estimate of the asymptotic covariance matrix of the sample variances and covariances (*LISREL 8.5*; cf. Jöreskog, & Sörbom [49]).

4. DATA ANALYSES

4.1 Discriminant validity

The first SEM aimed at demonstrating discriminant validity between the constructs using a confirmatory factor analysis (CFA) approach. The CFA model based on eleven variables and six latent constructs showed a good fit (Table 1).

TABLE 1. Indexes of fit of the latent constructs ($N = 207$)

χ^2	dl	p	χ^2/df	RMSEA	$p(\text{RMSEA} < .05)$	SRMR	AGFI	NFI	NNFI	CFI	ECVI
25.93	31	.72484	.8365	.000	.98	.032	.95	.96	1.01	1.00	.49<.64

Note. Thresholds: RMSEA $\leq .08$ or, better, $\leq .05$; $p(\text{RMSEA} < .05) > .50$; SRMR $< .05$; AGFI $> .85$: acceptable mod., $> .90$: good mod.; NFI $> .9$: acceptable mod., $> .95$: good mod.; NNFI: $> .95$: acceptable mod., $> .97$: good mod.; CFI $> .95$: acceptable mod., $> .97$: good mod.; ECVI: value lower than the saturated model.

The correlation matrix between latent constructs, disattenuated for measurement error, was inspected to verify the discriminant validity between the constructs (Table 2). All values were satisfying, the highest being .69.

TABLE 2. ϕ correlations, S errors, and t values for latent constructs ($N = 207$)

Constr.	att	pbc	se	intp	imis inner st	actions	ρ_c
att	1						.82
pbc	-.03 (.07)	1					.80
se	-.16 (.08)	.03 (.08)	1				-
intp	-2.11 .19 (.08)	.35 .22 (.09)	.27 (.09)	1			-
imis inner st	2.24 .36 (.09)	2.54 .08 (.10)	2.92 .20 (.10)	.24 (.10)	1		.65
actions	3.92 .24 (.09)	0.83 .00 (.09)	2.02 .19 (.09)	2.37 .27 (.09)	.69 (.09)	1	.76
	2.59	.03	2.03	2.98	7.74		

Note. Constr. = Constructs; att = attitude; pbc = perceived behavioural control; se = self-efficacy; intp = intentions to pass exams; imis inner st. = implementation intentions geared at controlling inner states; actions = behaviours of inner states control. Significant correlations are reported in bold.

The composite reliabilities for latent variables measured by more than one item (attitude, implementation intentions, and actions)² were calculated in using the information on the indicator loadings and error variances from the completely standardized solutions³.

² A reliability of .85 was arbitrary assigned to latent variables indicated by a single item and only their variance was estimated (Jöreskog & Sörbom [49]).

³ $\rho_c = (\sum \lambda)^2 / [(\sum \lambda)^2 + \sum (\theta)]$ where ρ_c = composite reliability; λ = indicator loadings; θ = indicator error variances; \sum = summation over the indicators of the latent variable.

4.2 Test of the TPB (*Basic TPB Models*)

The TPB model (*Basic TPB Model 1*) corresponding to the classical TPB showed a good fit to the data (Table 3). The χ^2 was not significant and all other indices were good. All the paths were significant at $p < .05$. The variance predicted in intention was 20 % of the total. However, the variance predicted in performance was not very substantial: 5.5 %, clearly less than mean results of Sheeran's [16] meta-analysis (28%). Adding a path from attitude to dependant variable ($\beta = .23$) improved the fitting of this model to data (*Basic TPB Model 2*). The χ^2 difference between the latter and the nested model was significant ($\Delta \chi^2_1 = 6.7, p < .005$) indicating that the freed parameter constituted a real improvement. The amount of explained variance was raised to 10%. Addition of a direct path from PBC to the dependant variable did not improve the fit.

TABLE 3. Indexes of fit of the models ($N = 207$)

Model	χ^2	dl	p	χ^2/df	RMSEA	p(RMSEA < .05)	SRMR	AGFI	NFI	NNFI	CFI	ECVI
Basic Model 1	21.16	16	.17258	1.323	.040	.62	.053	.94	.94	.96	.98	.30 < .35
Basic Model 2	14.46	15	.49076	.964	.000	.86	.035	.96	.96	1.00	1.00	.28 < .35
Volitional PB Model	49.26	47	.38295	1.481	.015	.96	.050	.93	.93	.99	.99	.54 < .76

Note. Thresholds: RMSEA $\leq .08$ or, better, $\leq .05$; $p(\text{RMSEA} < .05) > .50$; SRMR $< .05$; AGFI $> .85$: acceptable mod., $> .90$: good mod.; NFI $> .9$: acceptable mod., $> .95$: good mod.; NNFI: $> .95$: acceptable mod., $> .97$: good mod.; CFI $> .95$: acceptable mod., $> .97$: good mod.; ECVI: value lower than the saturated model.

4.3. Test of the Volitional Planned Behaviour Model (VPBM)

The VPBM consisted in introducing in the *Basic PBM2* IMIs geared at controlling potentially interfering motivational inner states as antecedents of actions specified in the *then*-component. The modification indices offered by the program suggested adding a path from attitude to IMIs. So modified, the model provided an excellent fit to the data (Table 3 and Fig. 1).

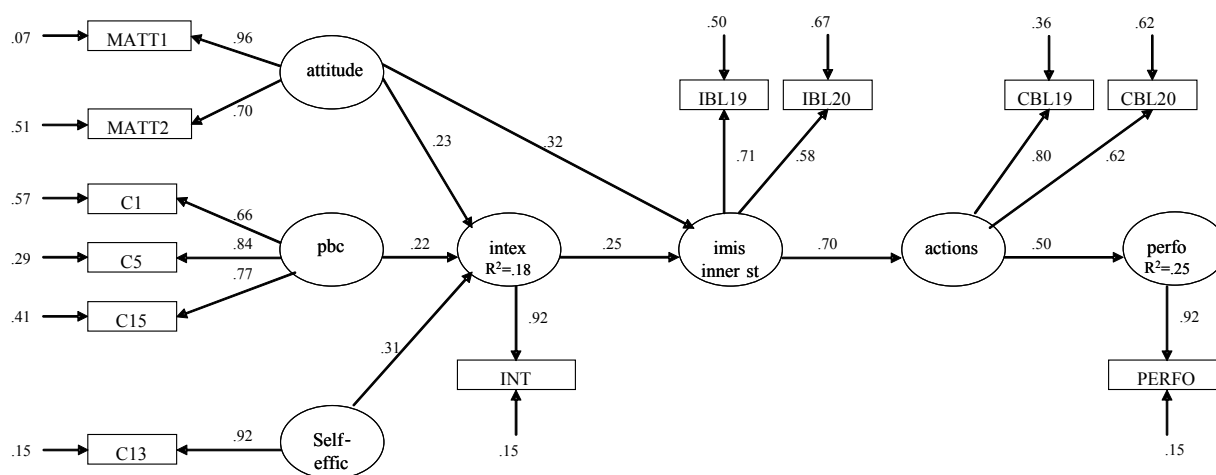

Fig. 1. VPB Model

$\chi^2 = 49.26, df = 47, p = .38295, RMSEA = .015$

Note. All paths significant at $p < .05$.

All the hypotheses were confirmed:

- IMIs were positive antecedents of actions specified in the *then*-component (H1);
- IMIs totally mediated the effects of TPB classical variables on performance (H2): in particular, attitude and intention directly triggered the IMIs which shield goal striving from unwanted thoughts;
- the hole model raised the amount of explained variance of exams marks to 25%, i.e., 15 % more than the *Basic PBM2* (H3).

5. CONCLUSION

This study was conducted in field settings and concerned important personal goals whose accomplishment relies on determined striving, namely performance in an academic context.

Some inner states are known to strongly imperil goal attainment. Accordingly, it was investigated whether inner states which could impair study could be specified in the *if*-component of IMIs and linked to an effective shielding response in the *then*-part. As explained by Achtziger *et al.* [44], “[o]ne does not need to anticipate what kind of external disruptive event will ultimately threaten one’s goal striving at hand to form a protective implementation intention. Rather, the disruptive inner states (e.g., performance anxiety) generated by these negative events can be used as a summary label and placed in the *if*-component of a protective implementation intention” (pp. 382-383). The present research built upon Achtziger *et al.* studies, but went beyond showing that IMIs of that kind mediate the effects on academic performance of attitude, perceived behavioural control, self-efficacy, and simple intention of the TPB.

Moreover these IMIs increased the amount of explained variance of performance above the contribution of the constructs of TPB, indicating that the gap between intentions and behaviour can be filled with IMIs.

One limitation of the present research is the absence of model cross-validation involving fitting the model to a fresh data set (Diamantopoulos & Siguaw [50]). Another limitation is the specificity of the sample. Other studies ought to be conducted on other samples to validate its generalisability.

Finally, an important step will be to explore the potential power of IMIs of exerting effect on study strategies. Learning strategies are the means by which a student organizes, acquires, and integrates new information. In a TPB design (Orbell [51]), volitional components such as conscious attention control, implicit attention control, and self-determination have been proved to increase explained variance of study behaviours by 18 %. Do IMIs from unwanted thoughts and feelings trigger these strategies? This is an exciting experimental challenge.

REFERENCES

1. Abraham, C., Sheeran, P., & Johnston, M. (1998). From health beliefs to self-regulation: Theoretical advances in the psychology of action control. *Psychology & Health, 13*, 569-591.
2. Austin, J. T., & Vancouver, J. B. (1996). Goal constructs in psychology: Structure, process, and content. *Psychological Review, 120*, 338-375.
3. Eagly, A. H., & Chaiken, S. (1993). *The psychology of attitudes*. Forth Worth, TX: Harcourt Brace Jovanich.
4. Gollwitzer, P. M., & Moskowitz, G. B. (1996). Goal effects on action and cognition. In E. T. Higgins & A. W. Kruglanski (Eds.), *Social Psychology. Handbook of basic principles* (pp. 361-399). New York, London: The Guilford Press.
5. Triandis, H. C. (1980). Values, attitudes and interpersonal behavior. In H. Howe & M. Page (Eds.), *Nebraska symposium on motivation* (Vol. 27, pp. 195-259). Lincoln: University of Nebraska Press.
6. Fishbein, M., & Ajzen, I. (1975). *Belief, attitude, intention and behavior: An introduction to theory and research*. Reading, MA: Addison-Wesley.
7. Ajzen, I. (1991). The theory of planned behavior. *Organizational Behavior and Human Decision Processes, 50*, 179-211.
8. Ajzen, I. (1985). From intentions to action: A theory of planned behavior. In J. Kuhl & J. Beckman (Eds.), *Action control: From cognition to behavior* (pp. 11-39). Berlin: Springer-Verlag.
9. Ajzen, I., & Madden, T. J. (1986). Prediction of goal directed behavior: Attitudes, intentions, and perceived behavioral control. *Journal of Experimental Social Psychology, 22*, 453-474.
10. Bandura, A. (1977). Self-efficacy: Toward a unifying theory of behavioral change. *Psychological Review, 84*, 191-215.
11. Armitage, C. J., & Conner, M. (2001). Efficacy of the theory of planned behavior: A meta-analytic review. *British Journal of Social Psychology, 40*, 471-499.
12. Godin, G., & Kok, G. (1996). The theory of planned behavior: A review of its applications to health-related behaviors. *American Journal of Health Promotion, 11*, 87-98.
13. Sutton, S. (1998). Predicting and explaining intentions and behavior: How well are we doing? *Journal of Applied Social Psychology, 28*, 1317-1338.

14. Fishbein, M. (1980). A theory of reasoned action: Some applications and implications. In H. Howe & M. Page (Eds.), *Nebraska Symposium on Motivation* (Vol. 27, pp. 65-116). Lincoln: University of Nebraska Press.
15. Floyd, D. L., Prentice-Dunn, S., & Rogers, R. W. (2000). A meta-analysis of research on protection motivation theory. *Journal of Applied Social Psychology, 30*, 407-429.
16. Sheeran, P. (2002). Intention-behavior relations: A conceptual and empirical review. In W. Stroebe & M. Hewstone (Eds.), *European Review of Social Psychology* (Vol. 12, pp. 1-36). Chichester: Wiley.
17. Cohen, J. (1992). A power primer. *Psychological Bulletin, 112*, 155-159.
18. Gollwitzer, P.M., & Sheeran, P. (2006). Implementation intentions and goal achievement: A meta-analysis of effects and processes. *Advances in Experimental Social Psychology, 38*, 69-119.
19. Webb, T. L., & Sheeran, P. (2004). Identifying good opportunities to act: Implementation intentions and cue discrimination. *European Journal of Social Psychology, 34*, 407-419.
20. Sideridis, G. D., Kaissidis-Rodafinos, A., & Padelidiadu, S. (1998). Comparison of the theories of reasoned action and planned behavior. *British Journal of Educational Psychology, 68*, 563-580.
21. Sideridis, G. D., & Kaissidis-Rodafinos, A. (2001). Goal importance within planned behavior theory as 'the' predictor of study behavior in college. *British Journal of Educational Psychology, 71*, 595-618.
22. Perugini, M., & Bagozzi, R. P. (2001). The role of desires and anticipated emotions in goal-directed behaviors: Broadening and deepening the theory of planned behavior. *British Journal of Social Psychology, 40*, 79-98.
23. Leone, L., Perugini, M., & Ercolani, A. P. (1999). A comparison of three models of attitude-behavior relationships in studying behavior domain. *European Journal of Social Psychology, 29*, 161-189.
24. Philips, P., Abraham, C., & Bond, R. (2003). Personality, cognition, and university students' examination performance. *European Journal of Personality, 17*, 435-448.
25. Kuhl, J. (1985). Volitional mediators of cognition-behavior consistency: Self-regulatory processes and action versus state orientation. In J. Kuhl & J. Beckmann (Eds.), *Action control: From cognition to behavior* (pp. 101-128). Berlin: Springer-Verlag.
26. Kuhl, J. (2000). A functional-design approach to motivation and self-regulation: The dynamic of personality systems interactions. In M. Boekaerts, P. R. Pintrich, & M. Zeidner (Eds.), *Handbook of self-regulation* (pp. 111-169). San Diego, CA: Academic Press.
27. Zhu, J. (2004). Locating volition. *Consciousness and Cognition, 13*, 302-322.
28. Kuhl, J., & Beckmann, J. (1985). Historical perspectives in the study of action control. In J. Kuhl & J. Beckmann (Eds.), *Action control: From cognition to behavior* (pp. 89-100). Heilderberg, New York: Springer-Verlag.
29. Oettingen, G., & Gollwitzer, P. M. (2001). Goal setting and goal striving. In A. Tesser and N. Schwarz (Eds.), *Intraindividual processes. Volume I of the Blackwell Handbook in Social Psychology*. M. Hewstone and M. Brewer (Eds.) (pp. 329-347). Oxford: Blackwell.
30. Gollwitzer, P.M., & Oettingen, G. (2000). The emergence and implementation of health goals. In P. Norman, C. Abraham, & M. Conner (Eds.), *Understanding and changing health behavior. From health beliefs to self-regulation* (pp. 229-260). Amsterdam: Harwood academic publishers.
31. Gollwitzer, P. M. (1990). Action phases and mindsets. In E. T. Higgins & R. M. Sorrentino (Eds.), *Handbook of motivation and cognition* (Vol. 2, pp. 53-92). New York: Guilford.
32. Heckhausen, H. (1991). *Motivation and action* Berlin: Springer-Verlag (Engl. tr. by P. Leppman of *Motivation und Handeln*, 2nd. ed., Berlin: Springer-Verlag, 1989).
33. Heckhausen, H., & Gollwitzer, P. M. (1987). Thought contents and cognitive functioning in motivational versus volitional states of mind. *Motivation and Emotion, 11*, 101-120.
34. Kuhl, J. (2002). A functional design approach to motivation and self-regulation. In M. Boekaerts, P. R. Pintrich, & M. Zeidner (Eds.), *Handbook of self-regulation* (pp. 111-169). San Diego: Academic press.
35. Broonen, J.-P. (2007). Le passé et l'avenir du concept de volition pour la psychologie de l'éducation et de la formation. *Les Cahiers Internationaux de Psychologie Sociale, 74*, 3-17.
36. Gollwitzer, P.M., Bayer, U.C., & McCulloch, C. (2005). The control of the unwanted. In R. Hassin, J. Uleman, & J. A. Bargh (Eds.), *The new unconsciousness* (pp. 485-515). Oxford, UK: Oxford University Press.
37. Gollwitzer, P. M. (1993). Goal achievement: The role of intentions. In W. Stroebe & M. Hewstone (Eds.), *European Review of Social Psychology* (Vol. 4, pp. 141-185). Chichester: Wiley.
38. Gollwitzer, P. M. (1996). The volitional benefits of planning. In P. M. Gollwitzer and J. A. Bargh (Eds.), *The psychology of action: Linking cognition and motivation to behavior* (pp. 287-312). New York: Guilford.
39. Gollwitzer, P. M. (1999). Implementation intentions: Strong effects of simple plans. *American Psychologist, 54*, 493-503.
40. Gollwitzer, P. M., & Brandstätter, V. (1997). Implementation intentions and effective goal pursuit. *Journal of Personality and Social Psychology, 73*, 186-199.
41. Orbell, S., Hodgkins, S., & Sheeran, P. (1997). Implementation intentions and the theory of planned behavior. *Personality and Social Psychology Bulletin, 23*, 953-962.
42. Sheeran, P., & Orbell, S. (1999). Implementation intentions and repeated behavior: Augmenting the predictive validity of the theory of planned behavior. *European Journal of Social Psychology, 29*, 349-369.
43. Bayer, U. C., & Gollwitzer, P. M. (2007). Boosting scholastic test scores by willpower: The role of implementation intentions. *Self and Identity, 6*, 1-19.

44. Achziger, A., Gollwitzer, P. M., & Sheeran, P. (2008). Implementation intentions and shielding goal striving from unwanted thoughts and feelings. *Personality and Social Psychology Bulletin*, *34*, 381-393.
45. Brandstätter, V., Lengfelder, A., & Gollwitzer, P.M. (2001). Implementation intentions and efficient action initiation. *Journal of Personality and Social Psychology*, *81*, 946-960.
46. Dubois, D. M. (2008). New trends in computing anticipatory systems: Emergence of artificial conscious intelligence with machine learning natural language. In D. M. Dubois (Ed.), *Computing Anticipatory Systems: CASYS'07. Eighth International Conference.*, AIP Conference Proceedings Vol. 1051, pp. 25-32. American Institute of Physics, Melville, NY.
47. Bagozzi, R. P., & Heatherton, T. F. (1994). A general approach to representing multifaceted personality constructs: Application to state self-esteem. *Structural Equation Modeling*, *1*, 35-67.
48. Boomsma, A., & Hoogland, J. J. (2001). The robustness of LISREL modeling revisited. In R. Cudeck, S. Du Toit, & D. Sörbom (Eds.), *Structural equation models: Present and future. A Festschrift in honor of Karl Jöreskog* (pp. 139-168). Chicago: Scientific Software International.
49. Jöreskog, K., & Sörbom, D. (2003). *LISREL 8.54*. Scientific Software International. Copyright 2003.
50. Diamantopoulos, A., & Siguaw, J. A. (2000). *Introducing LISREL. A guide for the uninitiated*. London: Sage.
51. Orbell, S. (2003). Personality systems interactions theory and the theory of planned behavior: Evidence that self-regulatory volitional components enhance enactment of studying behavior. *British Journal of Social Psychology*, *42*, 95-112.