

# A Selective and Highly Sensitive MIR Photoacoustic Sensor for Trace Gas Monitoring

M. Lassen<sup>1</sup>, L. Lamar<sup>2</sup>, D. Balslev-Harder<sup>1</sup>, P. Feng<sup>3</sup>, J.-F. Focant<sup>4</sup>, A. Peremans<sup>2</sup> and J. C. Petersen<sup>1</sup>

<sup>1</sup>Danish Fundamental Metrology, Matematiktorvet 307, DK-2800 Kgs. Lyngby, Denmark

<sup>2</sup>Laserspec BVBA, name of organization, acronyms acceptable, Namur, Belgium (*please check this*)

<sup>3</sup>COPAC ApS, name of organization, acronyms acceptable, City, Country (*please check this*)

<sup>4</sup>University of Liege, Allee du 6 août, B6, 4000 Liege, Belgium (*please check this*)

e-mail: [ml@dfm.dk](mailto:ml@dfm.dk)

**Abstract**— A highly sensitive, and selective photoacoustic (PA) sensor pumped by a single-mode mid-infrared (MIR) ns pulsed optical parametric oscillator (OPO) has been developed. The sensor has a wide tuning range covering absorption bands for a large number of molecules. The potential sensor applications include climate, environmental, and industrial monitoring and monitoring of exhaled breath for medical diagnostics. The sensor has been validated by monitoring acetone, formaldehyde, butane, propane, methanol, nitrogen dioxide, and methane.

## I. INTRODUCTION

Sensitive trace gas detection is very important and finds application within urban air quality and emission monitoring, industrial gas detection, food processing, security monitoring, breath analysis, to mention a few cases. Ideally sensors are expected to be cheap, portable, miniaturized, automated stand-alone devices, which are highly sensitive and species selective. For this innovative photoacoustic (PA) sensing is very promising technology [1, 2]. A newly developed broadly tunable MIR OPO source has been used for the measurements of various molecular species, including acetone, formaldehyde, butane, propane, methanol, nitrogen dioxide, and methane [3]. Spectra of both individual molecules as well as complex mixtures of various molecules were measured in the MIR wavelength range. The gasses measured are all interesting for health diagnostic and/or environmental monitoring.

## II. EXPERIMENTAL SETUP

The MIR OPO and the PAS cell are the central elements of the sensor. The MIR pulsed OPO is a single mode source, based on periodically polled LiNBO<sub>3</sub> crystal and provides a bandwidth of less than 1 cm<sup>-1</sup>. The repetition rate can be changes continuously from 10 kHz to 80 kHz, with 10-20 ns pulse duration depending on the repetition rate. The continuous tuning ability of the OPO repetition rate allows for synchronizing with the acoustic resonance of the PAS cell, in equivalence with a modulated continuous-wave light PAS setup. The OPO is tunable from 3100 nm to 3800 nm and delivers up to 3W of average optical power. The acoustic resonator is designed to resonantly amplify the acoustic signal generated in the gas as a result of absorption of the modulated light [3].

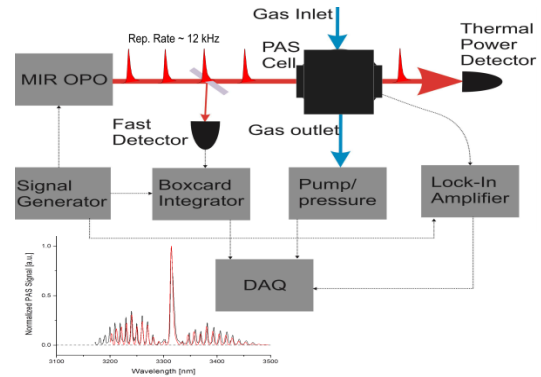

## III. EXPERIMENTAL RESULTS

Measurement results of acetone, butane, formaldehyde, propane, methanol, nitrogen dioxide, and methane will be presented including mixtures of these gases. We demonstrate that the PA sensor can resolve the various molecular spectra with an instrument limited bandwidth of 1 cm<sup>-1</sup>, thus allowing for differentiation of the individual gasses in a complex mixture. It is demonstrated that the PA sensor exhibit gas concentration sensitivities at the ppb level for the PA sensor are demonstrated.

## Acknowledgment

This work was supported by EUREKA (Eurostars program: E9117 – NxPAS) and the Danish Agency for Science Technology and Innovation.

## REFERENCES

- [1] M. Lassen et al., Phase-sensitive noise suppression in a photoacoustic sensor based on acoustic circular membrane modes, *Applied Optics*, Vol. 54, Issue 13, pp. D38-D42 (2015)
- [2] M. Lassen et al., A versatile integrating sphere based photoacoustic sensor for trace gas monitoring, *Optics Express*, 22, 11660-11669 (2014)
- [3] M. Lassen et al., Photoacoustic Sensor as a noninvasive and real-time Diagnostic Tool for Health Care, under preparation (2016)