

# **Evidence-based calibration of a building energy simulation model: Application to an office building in Belgium**

S. Bertagnolio<sup>1</sup>, F. Randaxhe<sup>1</sup> and V. Lemort<sup>1</sup>

<sup>1</sup> *Energy Systems Research Unit  
Thermodynamics Laboratory  
University of Liege – Sart Tilman Campus B49-P33  
Liege, Belgium*

Email: [stephane.bertagnolio@ulg.ac.be](mailto:stephane.bertagnolio@ulg.ac.be)

## **Abstract:**

Energy services play a growing role in the control of energy consumption and the improvement of energy efficiency in non-residential buildings. This work consists in the application of a simulation-based approach dedicated to whole-building energy use analysis for use in the frame of an energy efficiency service process. Focus is given to the calibration of a simplified dynamic hourly building energy simulation model by means of available energy use data and to the integration of the calibration process into the Energy Service Process. The developed simulation tool and the associated calibration method are applied to a real case study building located in Brussels, Belgium. The use of an evidence-based method ensures sticking to reality and avoids bad representation and hazardous adjustment of the parameters. Moreover, it is shown that the use of a sensitivity analysis method is of a great help to orient data collection and parameters adjustment processes.

## **Keywords:**

Building energy services, energy use analysis, calibration, modeling, simulation

## **1. Introduction**

Environmental concerns and the recent increase of energy costs open the door to innovative techniques to reduce energy consumptions. Buildings represent about 40% of the European energy consumption (Perez-Lombard, 2008). Non-residential buildings are part of the main energy consumers and improvement of their energy performance is a major challenge of the 21<sup>th</sup> century. To this end the European Commission approved the European Directive on Energy Performance of Buildings (EPBD, 2002) on 16 December 2002. In 2006, the European Commission approved a second directive (Directive 2006/32/EC) promoting the development of a market for energy services in the member states in order to improve the energy efficiency in the building sector and support the energy demand management.

EN15900 describes Energy Efficiency Services (EES) as a process based on collected energy use data, designed to achieve an energy efficiency improvement and including a series of steps such as: (1) Energy audit or inspection, (2) Measurement and verification of implemented Energy efficiency improvement action(s) and (3) Periodic verification of the energy performance of the building and continuous operation optimization.

Most of the steps of the energy efficiency service process require on-field measurements and energy use analysis. Today, while detailed on-field measurements and energy counting stay

generally expensive and time-consuming, energy simulations are increasingly cheaper due to the continuous improvement of computer speed.

Performance verification protocols (IPMVP, ASHRAE 14...) encourage the use of simulation models to evaluate the energy performance of existing buildings provided they are able to represent the actual situation with an acceptable accuracy. The fitting of a BES model to an existing situation involves using as-built information, survey observations and short and/or long term monitoring data to iteratively adjust the parameters of the BES model. This process is generally known as “calibration”.

Ahmad and Culp (2006) have developed a blind time-limited test protocol to evaluate the range of discrepancies encountered when using uncalibrated simulations (between 30% and 90% when predicting total or specific energy usages) and shown that it is not possible to trust uncalibrated simulation models when studying an existing situation.

In the present paper, the development and the calibration of a simplified dynamic hourly building energy simulation model by means of available energy use data are presented. The proposed evidence-based calibration methodology is deeply related to on-field inspection and data collection issues and is developed to fit with the audit/inspection process. The developed simulation tool and the associated calibration method are applied to a real case study building located in Brussels, Belgium.

## **2. Simulation Tool and Calibration Methodology**

### ***2.1. Simple dynamic hourly simulation model***

The calibration of a simulation model to an existing situation is usually a highly underdetermined problem. Indeed, only very scarce and limited information are usually available about the building (e.g. as-built files) and its performance (e.g. monthly energy billing data) while the number of parameters to adjust is generally high.

Popular commercial building energy simulation software's do not generally suit to the study of existing situations. Most of these simulation packages have been developed to support the design of new buildings and often include numerous details and aspects that cannot be investigated in practice. A simplified building energy simulation model has been designed and developed so as to fit with the requirements of whole-building energy use analysis (i.e. prediction of hourly heating and cooling needs and subsequent final energy consumptions) while minimizing the amount of parameters to adjust (Bertagnolio et al., 2010).

The quasi-steady state hourly simulation program developed in this work is based on the LSPE (loads - secondary system - primary system - economics) sequential approach (Reddy and Maor, 2006) and relies on simple normative models (e.g. ISO13790 simple dynamic hourly building model). The heating, cooling and latent loads computed by the building zone model are summed and converted into system loads and then, into final energy consumptions (Fig.1). This approach allows minimizing the number of iterations needed to simulate the performance of the building and its system.

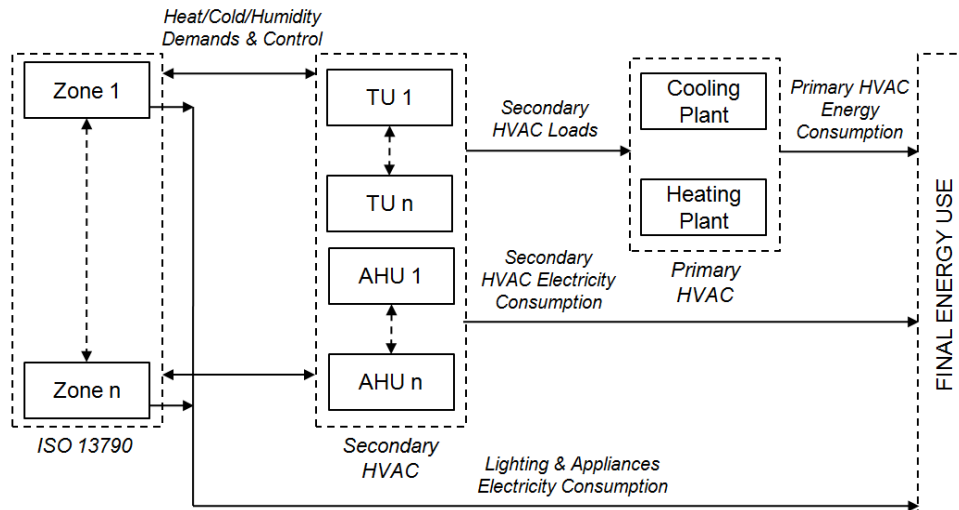

Fig. 1. Global building-HVAC model block diagram

When compared to reference detailed building simulation models (e.g. Trnsys, EnergyPlus...), the simplified model demonstrated an accuracy of less than 8% when predicting annual heating and cooling needs (Bertagnolio, 2012).

## 2.2. Evidence-based calibration method

The calibration of a forward building energy simulation model remains a complex and highly underdetermined problem. In other words, even if the “net effect” of all the “knobs” may yield to a simulated output close to the measured one, there is no guarantee that all individual “knobs” are properly tuned. Even if a special attention has been paid to select easily identifiable parameters with a physical meaning, the number of parameters to calibrate remains important in comparison with the very limited amount of available data (e.g. monthly energy bills).

Because of the complexity of the problem, the four following issues are considered as crucial when performing a calibration:

- Reproducibility and robustness, ensuring the method is systematic and may be applied to numerous cases;
- Sensitivity issues, consisting in distinguishing influential and non-influential parameters;
- Uncertainty issues, consisting in characterizing or quantifying the final uncertainty on the model’s outputs;
- Accuracy issues, related to the definition of the calibration criterion that will be used to estimate the quality of the calibrated model.

In the present work, a systematic evidence-based calibration method making intensive use of sensitivity and (non-intrusive) measurement issues is developed (Fig. 2). The calibration work starts by setting up the initial as-built input file based on available information (architectural plans, as-built files, technical sheets...). Generally, this first simulation run provides results with an accuracy of about 30% (Ahmad and Culp, 2006) in terms of annual energy use. This as-built input file is then used as a basis for the sensitivity analysis phase. Indeed, the parameters of the model are characterized by “best-guess” values (i.e. the best approximation

of the parameter based on the available information) and “uncertainty ranges” expressing the doubts about the considered values.

The next steps of the calibration methodology relies on the definition of two types of hierarchy:

- A hierarchy between influential and non-influential parameters: sensitivity analysis is used (1) to distinguish influential and non-influential parameters (non-influential parameters are then fixed to their best-guess value following a factor fixing approach) and (2) to classify the influential parameters by order of importance (screening) in order to orient on-site data collection work;
- A hierarchy between the sources of information exploited to identify the parameters: Priority is given to physical observation and measurements. Adjustment of a parameter is done only if the value consists in an “improvement” of the quality/reliability of the model (i.e. the updated value has a physical meaning and has been obtained from a more reliable source of information, e.g. direct measurement, than the previous one, e.g. on-site observation).

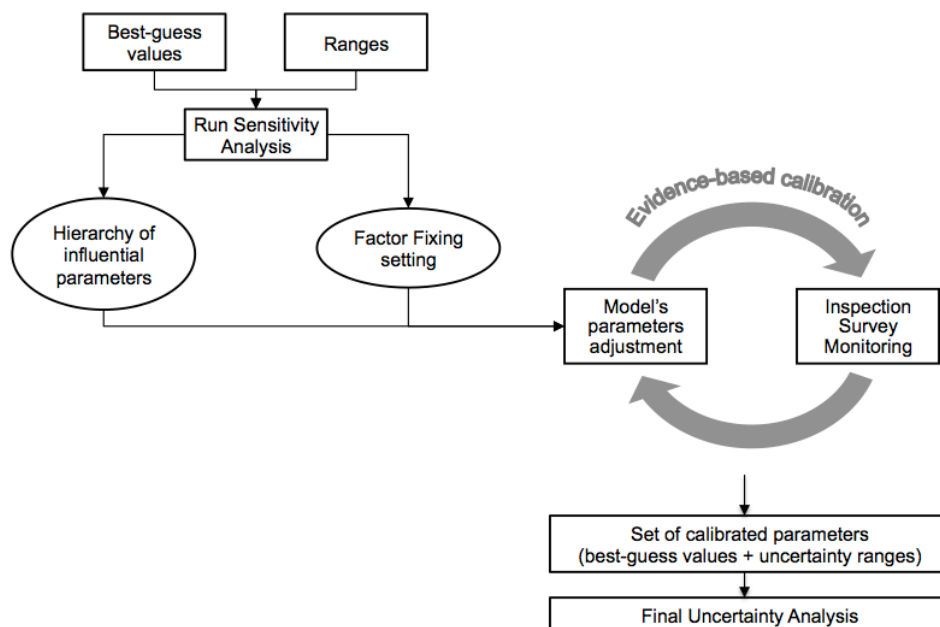

Fig. 2. Evidence-Based Calibration Methodology

Even if the model is not highly non-linear, the interaction effects have to be characterized in order to provide good guidance for calibration and a global sensitivity method has to be used. The Morris’ sensitivity analysis method (1991) is used to identify and hierarchize the most influential parameters of the model. This method was found to be suitable for application to BES models by De Wit (1997) since it is not dependent on the properties of the model and does not require any assumption regarding linearity or correlations between the inputs and the outputs of the model.

Heiselberg and Brohus (2007) also highlighted other advantages for the Morris method:

- The method can handle large number of parameters and requires a relatively limited amount of simulation runs;

- The parameters are varied globally within the range and the whole parametric space can be explored without pre-defining the probability density function of each parameter;
- The results are easily interpreted and visualized graphically as prescribed by Morris (1991).

The sensitivity of the output is characterized by a value called “Elementary Effect”. The effect of a given parameter is calculated several times, at randomly selected points of the parametric space. The mean value of the effect is then compared to the dispersion (standard deviation) in order to allow the selection of the most influential parameters and the distinction of parameters with linear effects from parameters with nonlinear effects (i.e. interactions).

In the other hand, the Morris analysis does not allow uncertainty analysis because it does not take the shape of the probability density function of the parameters into account (De Wit et al., 2002). Indeed, the method cannot be considered as quantitative. The value of its measures can only be used to rank the studied parameters by order of influence and characterize the structure of the model but cannot be interpreted as percentages of the output variance.

After having been identified as an influential parameter, the value of the concerned parameter has to be refined and the uncertainty range on this parameter can be narrowed. If practically feasible, spot (SpotM) or short-term (STeM) monitoring has to be considered in priority in order to allow direct quantification of the parameter. If redundant data are collected, the “higher quality” information (i.e. the information judged as the most representative of the usual operation/behavior of the building) should be used to specify the best-guess value of the parameter. The other values should not be neglected and can be used for crosschecking. If the physical measurement is not possible for a given reason (e.g. because of money or time constraints), it is suggested to consider the next parameter by order of influence. Proceeding in such a way ensures that the procedure is “evidence-based” and that priority is given to physical measurement and not to highly questionable or hazardous “tuning” of the parameter.

Specifying (and narrowing) probability/uncertainty ranges for the parameters all along the calibration allows characterizing the quality of the calibrated model at each step of the process (since specified ranges “express” the quality of the information used to adjust the parameter). At the end of the process, when the calibration criteria have been satisfied and all the critical issues have been tackled through of the available means, an uncertainty analysis is run to quantify the final uncertainty on the model’s output following the Latin Hypercube Monte Carlo sampling method.

### ***2.3. Calibration Accuracy***

Several authors have studied the question of the definition of a criterion to assess the quality of calibration. It appeared that it is delicate (if not impossible) to define a general criterion, ensuring proper calibration of a given simulation model to a given existing situation. Usually, statistical indexes (MBE: Mean Bias Error and CVRMSE: Coefficient of Variation of the Root Mean Square Error) computed on annual or monthly basis (as prescribed by ASHRAE, 2002) are used as calibration criteria. However, such criteria are often considered as too cool or not representative enough of the quality of the calibrated model. In addition to this mathematical criterion, it is suggested to consider the following points to check the validity of the calibration:

- Computed peak heating and cooling loads have to be in good accordance with the installed heating/cooling capacities;
- If available, the recorded whole-building hourly electricity load should be compared to the computed values;
- Simulated daily/hourly energy use profiles (concerning internal gains, system operation, chiller load...) should be visually checked, criticized and confronted to the operating patterns observed (or measured) during the inspection phase.

### 3. Case Study

The main results of the application of the developed tools and methods to an existing office building located in Bruxelles (Belgium, Fig. 3) are summarized below. The building was built in the 70's and was largely refurbished in 1998 (complete modification of the HVAC system and a renovation of the facade and of the indoor space). The building is characterized by an annual primary energy consumption of about 316 kWh/m<sup>2</sup>/yr (slightly below the average for similar buildings in Brussels).



Fig. 3. Case Study Building (SW façade)

The net floor area of the building is about 10100 m<sup>2</sup> and is distributed over 9 floors and includes mainly office cells and meeting rooms. The ground floor mainly includes the entrance hall, a library, some meeting rooms and offices. Levels +1 to +8 mainly include office cells. At each level, the core zone is split in two parts and has a similar composition and includes some utility areas (stairs, elevators, sanitary, storage, kitchen, copy rooms...). The three basement levels (about 2534 m<sup>2</sup> each) mainly include parking areas.

Five main Air Handling Units (AHUs) serve the three main conditioned zones of the building:

- AHUs #1 and #2: The offices located at Levels +1 to +8
- AHUs #3 and #4: The ground floor peripheral zones (meeting zones, offices and library)
- AHU #5: The Entrance hall

AHUs #1 and #2 are Constant Air Volume (CAV) units and include adiabatic humidification systems. A fraction of the air extracted by these two units is sent back to the parking levels -1 and -3. The AHUs #3 and #4 are Variable Air Volume (VAV) units and serve the peripheral zones located at the ground floor. The fifth AHU (#5), serving the entrance hall, consists in a

small ventilation unit supplied with vitiated air extracted from the zone and a small fraction of fresh air coming from the AHU3. Four smaller ventilation units supply or extract air to/from auxiliary zones (parking, sanitarries, printshop...).

The peripheral zones located at the ground floor are equipped with VAV boxes controlling the supply airflow rate. Hot water convectors are installed all along the external walls (one per 2.4m of façade) to provide local heating to the peripheral zones. Cooling of the zones is ensured by increasing the supply airflow. Peripheral zones at levels +1 to +8 are equipped with vertical concealed 4-pipes heating/cooling fan coil units (one per façade module of 1.2m width).

Three natural gas boilers of 465 kW each ensure hot water production. Two classical boilers (#1 and #2) provide hot water to the AHUs heating coils and to the two air heaters located in the parking space. The third boiler is a condensing boiler and provides hot water to all the FCUs installed in the office zones (levels +1 to +8).

Chilled water production is ensured by two water-cooled chillers of 512.4 kW of cooling capacity each (rating EER: 4.27). Two indirect contact cooling towers equipped with two speeds fans ensure the cooling on the condenser side.

Monthly energy billing data, including natural gas, peak-hours electricity and off-peak-hours electricity consumptions, are available for 2008, 2009 and 2010. Whole-building quarter-hour peak electricity demand (in kW) is also available for these three years.

#### 4. Calibration of the BES model

Four calibration levels can be identified when constructing the model (Table 1):

- Level 1: as-built input file
- Level 2: inspection level (consisting in visits of the building and installation, survey of installed equipment and analysis of the Building Energy Management System)
- Level 3: monitoring level (using spot and short-term monitoring)
- Level 4: questionnaire-based occupancy survey

At each calibration level, both statistical criteria and visual verifications are used to analyze the accuracy of the calibrated model and point out the issues that should have been investigated in order to continue improving the model.

Table 1: Calibration levels and data availability

Calibration levels		Building description and performance data available for calibration					
		Utility bills <sup>1</sup>	WBE demand <sup>2</sup>	As-built data	Inspection	Spot/Short-term monitoring	Occupancy survey
Evidence-based process	Level 1	x	x	x			
	<b>Preliminary Sensitivity Analysis</b>						
	Level 2	x	x	x	x		
	Level 3	x	x	x	x	x	
	Level 4	x	x	x	x	x	x
<b>Final simulation results and uncertainty on the predicted energy use</b>							

<sup>1</sup> Natural gas, peak-hours and off-peak-hours electricity consumption (in kWh) provided on a monthly basis

<sup>2</sup> WBE (Whole-Building Electricity) demand (in W) provided by the electricity provided on a quarter-hour basis

#### 4.1. Level 1: as-built input file and preliminary Sensitivity Analysis (SA)

The initial input file is built based on the as-built information (complete description of building geometry, envelope and HVAC system using as-built and design information) but does not represent actual building use or operation and includes default values for lighting and appliances densities and schedules, as well as HVAC system setpoints and schedules. In order to reduce computation cost and parameterization work, similar zones and HVAC system components have been consolidated (e.g. consolidation of AHUs 1&2 and 3&4, two by two) following the rules proposed by Liu et al. (2004).

In addition to the so-called “best-guess” values, probability ranges have also been defined for each parameter of the model based on the (qualitative) uncertainty related to the source of the information in order to allow running uncertainty and sensitivity analyses. At this stage, conservative hypotheses have been made in order to define relatively large uncertainty ranges.

Table 2: Initial values and uncertainty ranges for some parameters

$IGFR_{light}$	W/m <sup>2</sup>	Lighting power density – Offices/meeting	12	-50%	+50%
$IGFR_{appl}$	W/m <sup>2</sup>	Appliances power density – Offices	10	-50%	+50%
$T_{i,set,h,occ}$	°C	Heating setpoint – Offices	21°C	-2°C	+2°C
$T_{i,set,h,nocc}$	°C	Heating setpoint (night) – Office	15°C	-2°C	+2°C
$T_{i,set,c, occ}$	°C	Cooling setpoint – Offices	25°C	-2°C	+2°C

For example, at this level, no information is available regarding the building use and operation. So, internal gains and corresponding schedules are set to default/typical values given in the literature (12 or 10 W/m<sup>2</sup>) and characterized by large probability ranges (+/- 50%). The same rule is used for internal temperature setpoints and HVAC system operation (Table 2). On the contrary, parameters known with a higher confidence are characterized by smaller intervals (e.g. envelope characteristics).

The defined set of values and ranges are used to generate a Morris sample for sensitivity analysis purposes. Relative influences of the parameters have been expressed in terms of impact on seasonal final electricity and natural gas consumptions. Impact on hot water and chilled water demands have also been studied in order to ensure a right representation of heating and cooling needs of the building by the calibrated model. Indeed, as shown in a previous study (Bertagnolio, 2012), even if gas consumption and heating needs are directly correlated, the relationship between cooling needs and electricity consumption is generally less direct. Hierarchy between most influential parameters is given in Table 3.

Table 3: Influential parameters hierarchized by order of influence

Parameter	Solar shading use	Supply T° setpoints	HVAC schedules	Heating Cooling setpoints	Occupancy schedules	Internal loads schedules	Internal loads densities	Ventilation rate
Influence								



These results are used to guide the data collection process (sort of “experimental design”) during the next steps of the calibration process. As the calibration progresses, collected data can be used to:

- Update the value of the given parameter if the new information is more reliable than the previous one (e.g. physical measurements vs default value; short-term monitoring vs BEMS recordings);
- (Cross)check the current value of the parameter if the quality level of the new information is lower (e.g. observation vs measurement; spot vs short-term monitoring data) or similar (e.g. spot monitoring performed at different moments).

As expected, the model based on the as-built input file is not reliable and consumption and demand profiles are badly predicted by the model. Moreover, the uncertainty on predicted electricity consumption disaggregation (quantification of relative consumption of main end-users) remains important (Fig. 4).

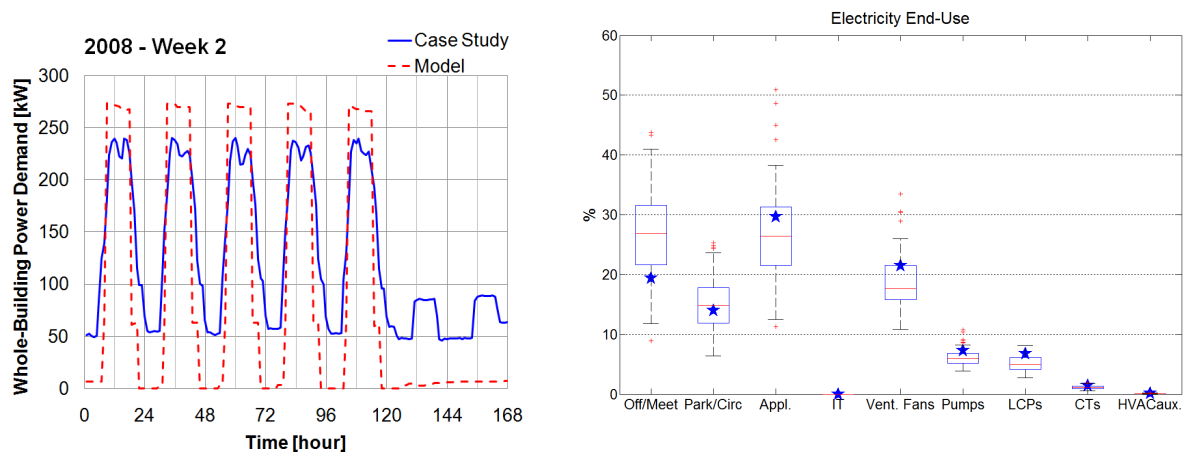

Fig. 4. Predicted vs Recorded WBE demand (in kW) for a winter week (left); uncertainty on predicted end-use electricity consumptions computed following the LHMC approach (right).

#### 4.2. Levels 2, 3 and 4: Inspection, Monitoring and Survey

At the inspection level and monitoring level, data collection is oriented by the results of the preliminary sensitivity analysis described above and focuses on building use (occupancy, lighting and appliances use) and operation (HVAC system setpoints and schedules).

The inspection allowed collecting additional information about the actual operation of the HVAC system (setpoints, schedules) and making a survey of the installed lighting and appliances powers. At the end of this inspection, the model was updated (and the uncertainty ranges of the concerned parameters were narrowed). The global quality of the model was improved but some shadow areas remain (e.g. occupancy and operation schedules...).

Following the inspection, a monitoring campaign was launched. Once again, focus was given to parameters identified as influential and important for calibration and measurements were implemented in order to:

- Improve the knowledge about actually achieved levels of temperature and humidity in the zones (by using local temperature and humidity sensors);

- Identify actual occupancy, lighting use and appliances use patterns (by means power demand monitoring at zone and floor level, Fig.5);
- Confirm/Check the values of some HVAC system components performance, setpoints and schedules (by means of power demand monitoring on different electrical boards).

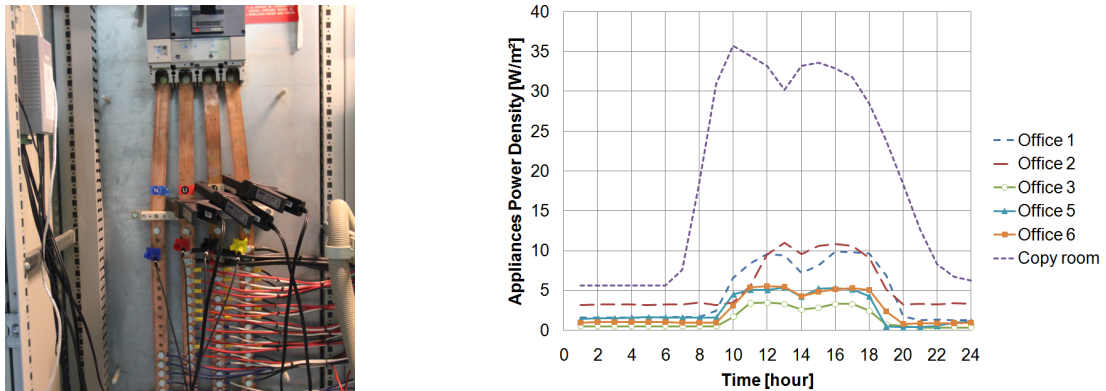

Fig. 5. Calibration Level 3: Installed electrical power logging device (left); Appliance power demand in several rooms for a typical day (right).

Because most of the measurements were done during winter, no information was available about the operation of the building during summer period. The last level of calibration included some information collected by means of a questionnaire sent to the occupants in order to characterize the level of occupancy (and activity) during summer holidays.

#### 4.3. Finals Results

At the end of the 4<sup>th</sup> level of calibration, the model seems to be able to represent the actual energy behavior of the building with an acceptable accuracy. Monthly consumption profiles and sub-hourly power demand profiles are well represented (Fig. 6). Statistical indexes (MBE and CV(RMSE)) are also relatively low and satisfy the accuracy criteria specified by ASHRAE (2002).

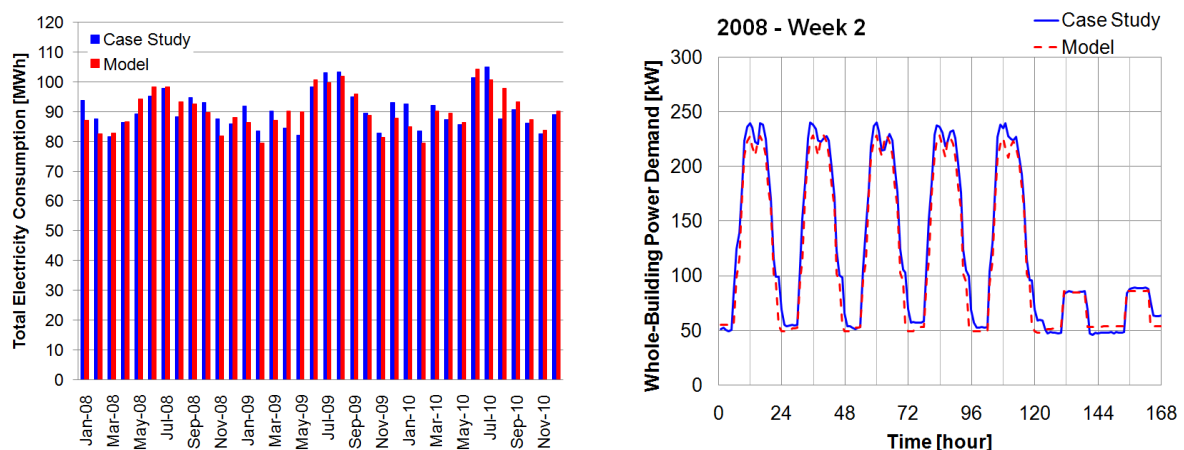

Fig. 6. Predicted (red) vs Recorded (blue) monthly electricity consumptions (left) and whole-building power demand (right).

It is interesting to have a look at the evolution of the major statistical indexes all along the calibration process. The impact of the adjustment of the parameters on the monthly MBE and

CV(RMSE) indexes is very clear during the first stages of the calibration process. After a certain time (level 3: use of monitoring data), the improvement of the quality of the model is not well translated anymore by the mathematical indexes computed on monthly basis (Fig.7 left) and visual verification becomes necessary to check the quality of the model. For step3a (and following), the adjustment of the model is done in order to fit to smaller time-scale data (i.e. monitoring data and whole-building power demand). At this moment, monthly global indexes become unable to catch the improvement of the model. On the contrary, continuous improvements of the model can be noticed when looking at the evolution of the same indexes computed on an hourly basis when comparing computed and recorded whole-building power demand (Fig.7 right).

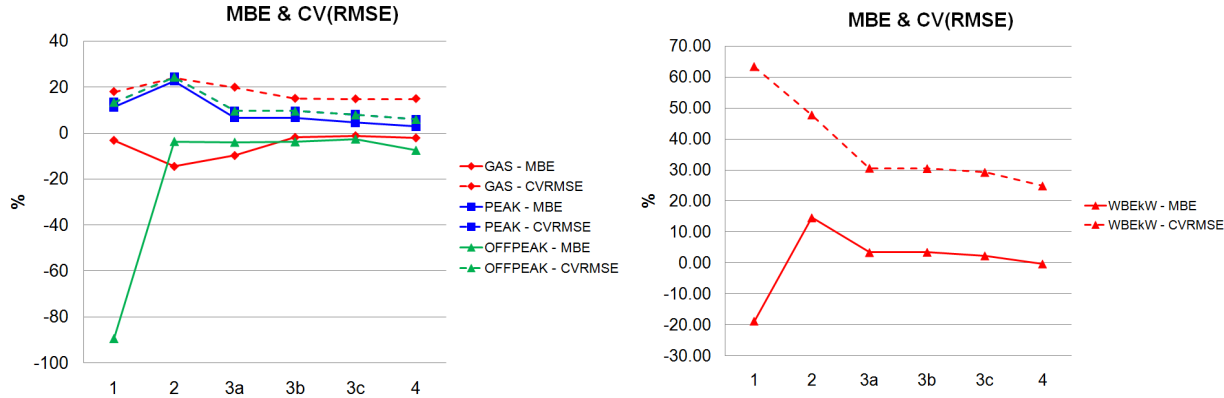

Fig. 7. Calibration levels 1 to 4: Evolution of the statistical indexes for monthly gas and electricity consumptions (left) and hourly whole-building power demand (right)

Calibrated model is then used to disaggregate whole-building electricity consumption (Fig.8). About 33% of the total electricity consumption is due to artificial lighting. Only one third of this part of the consumption is due to lighting in occupancy zones. Offices appliances (computers, printers...) represent about 16% of the total consumption while almost one quarter of the total consumption is due to IT rooms. Ventilation fans are responsible of about 14% of the consumption. The hot and chilled water production and distribution equipment represent about 13% of the total consumption.

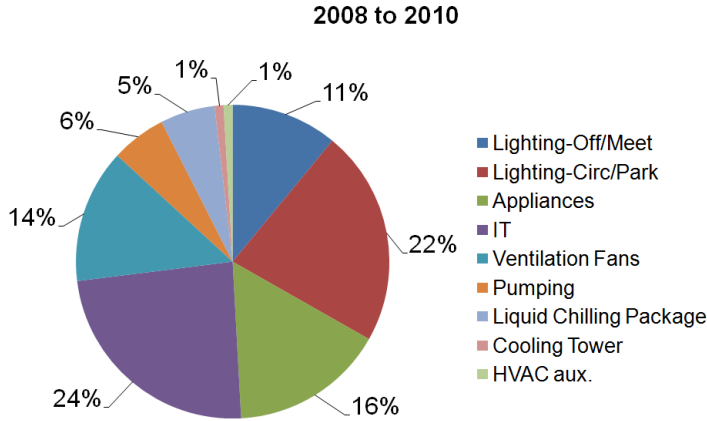

Fig. 8. Whole-building electricity consumption disaggregation

Some electricity users (such as elevators) have not been taken into account in the modeling and cannot be quantified by the simulation model. However, as shown above, the main energy

users installed in the building have been taken into account during the modeling phase and the energy use of the neglected ones should not represent more than a few percent of the total energy consumption (i.e. order of magnitude as the final calibration error).

The relative uncertainty (standard deviation) on predicted energy end-use is included between 2.5% and 17%. Lowest uncertainties (between 2.5% and 6%) correspond to internal gains, which have been subject to monitoring (and are characterized by narrowed uncertainty ranges). The energy uses of non-monitored electricity consumers (chillers, cooling towers...) or related to non-monitored energy needs (cooling needs) are characterized by higher uncertainties (between 6% and 17%).

## 5. Conclusion

The diversity of the buildings composing the non-residential building stock makes hard to derive a general automated calibration methodology that could fit all the cases encountered in practice. It is believed that a flexible evidence-based calibration is needed because:

- Inspection and monitoring needs could vary a lot from case to case, depending on the initial uncertainties on the building/system description;
- Various sources and types of data have to be collected (field observations, BEMS analysis, various types of loggers...) and treated to allow translation into parameters values;
- Statistical indexes that could be used to express an objective function in the frame of an optimization-based calibration approach are too global to reflect all the influences and interactions involved in the model;

This paper presents a new systematic evidence-based calibration methodology giving priority to the physical identification of the model's parameters (i.e. to the direct measurement) and relying on the notion of hierarchy among the source of information (as a function of their reliability) used to identify the parameters. The improved Morris' sensitivity analysis method is used for "factor fixing" (i.e. distinction between non-influential model's parameters) and "parameters screening" (i.e. classification of influential parameters by order of importance) in order to orient the data collection work and guide the parameters adjustment process.

The use of the proposed method and simulation tool ensures sticking to reality and avoids bad representation and hazardous adjustment of the parameters. The intensive use of a sensitivity analysis method is of a great help to orient data collection and parameters adjustment processes. Defining confidence/uncertainty ranges for each parameter, in addition to a "best-guess" value, also allowed quantifying the uncertainty on the final outputs of the model (by means of the LHMC method) and helped the user in evaluating the quality of the calibrated model and criticizing model outputs.

The application of the method to a building case study allowed clearly identifying the potential interactions between the calibration work and the data collection process. The use of a systematic evidence-based method including sensitivity issues allowed optimizing the efforts (i.e. minimizing the monitoring and modeling work while maximizing the quality of the model) and reaching an acceptable level of accuracy. The model was calibrated as the information and data were collected/available: both best-guess values and uncertainty ranges were progressively updated. Finally, the simulation results were analyzed and an uncertainty

analysis based on the LHMC method was performed in order to quantify the uncertainty on the final simulation results.

This case study confirmed that it is possible to calibrate a simplified hourly simulation model by means of a relatively little amount of physical measurements if focus is given to critical issues and a systematic and efficient approach is followed. Unfortunately, for practical reasons (loss or unavailability of monitoring equipment), it was not possible to perform, among others, indoor conditions measurements during summer.

In a near future, the next steps of this case study will consist in:

- Perform spot and short-term monitoring during the cooling period to identify the achieved levels of temperature in the zones;
- Setting up online long-term monitoring of the performance of the cooling system (in the frame of the iServ project, Knight 2011);
- Using the calibrated model to make continuous performance verification;
- Evaluating the impact of some modifications of the HVAC system.

### References:

- Ahmad, M., Culp, C.H. 2006. Uncalibrated Building Energy Simulation Modeling Results. HVAC&R Research, vol. 12, Nr. 4, pp. 1141-1155.
- ASHRAE. 2002. ASHRAE Guideline: Measurement of energy and demand savings. ASHRAE Guideline 14-2002.
- Bertagnolio, S. 2012. Evidence-Based Model Calibration for Efficient Building Energy Services. PhD Thesis, University of Liege, Belgium.
- De Wit, M.S. 1997. Identification of the Important Parameters in Thermal Building Simulation Models. Journal of Statistical Computation and Simulation, 57:1-4, pp. 305-320.
- De Wit, S., Augenbroe, G. 2002. Analysis of Uncertainty in Building Design Evaluations and its Implications. Energy and Buildings, 34, pp. 951-958.
- Efficiency Valuation Organization. 2007. International Performance Measurement and Verification Protocol (IPMVP). Concepts and Options for Determining Energy and Water Savings – Volume 1.
- Heiselberg, P., Brohus, H. 2007. Application of Sensitivity Analysis in Design of Sustainable Buildings. Proceedings of the International Conference on Sustainable Development in Building and Environment, Chongqing, China.
- ISO/FDIS 13790:2007. Energy performance of buildings – Calculation of energy use for space heating and cooling. International Standard Organization, Geneva, Suisse
- Knight, I. 2011. Inspection of HVAC System through continuous monitoring and benchmarking. <http://www.iservcmb.info>
- Liu, M., Song, L., Wei, G., Claridge, D.E. 2004. Simplified building and air-handling unit model calibration and applications. Journal of Solar Energy Engineering. Vol. 126, pp. 601-609.
- Morris, M. 1991. Factorial Sampling Plans for Preliminary Computational Experiments. Technometrics 33(2), pp. 161-174.
- Reddy, T.A., Maor, I. 2006. Procedures for reconciling computer-calculated results with measured energy data. ASHRAE Research Project 1051-RP. Atlanta: American Society of Heating, Refrigerating and Air-Conditioning Engineers, Inc.